



HEAR and LEARN
CLASSROOM SOUND ENHANCEMENT



955 Access™

Classroom Audio System
User Manual

www.hearandlearn.com.au

955 Access is part of the www.hearandlearn.com.au technology family.
Offices Australia wide (03)93709355

TABLE OF CONTENTS

SECTION 1:	4	Important Safety Instructions
Overview	5	955 Access: System Components and Unpacking
	6	Standard Components & Optional accessories
	9	Controls & Indicators
	11	Flexmike Controls and Connections
	12	Charging the Flexmike
SECTION 2:	14	Operating the Flexmike
Set-up and Use/	15	Using Flexmike as Wireless Audio Link
Daily Operation	16	Output to Assistive Listening Device (ALD)
	17	Audio Integration
	18	Daily Operation Instructions
SECTION 3:	19	Sharemike: Controls & Connections
Optional Accessories	20	Sharemike: Charging
	21	Sharemike: Initial Set-up
	21	Pagefirst Sensor
	24	Activate Station
	24	Controls & Connections
	24	Initial Set-up
	26	Charging Flexmikes
	27	Register New Components
	27	Download Mobile App
	28	Pairing Your Mobile Device
	29	Output to Assistive Listening Device
	30	Activate Station: Record and Capture
	30	Video + Audio Recording
	31	Audio Only Recording
	31	Photo Capture
	32	Recording Library and Playback
	34	Additional Capabilities with Activate App
	35	Audio Integration with Activate Station
	36	Activate with Pods for Small Group Instruction
	37	Media Connector: Controls and connections
	39	Media Connector: Initial Set-up
	40	Using the Media Connector
	41	Audio Integration with Media Connector
SECTION 4:	42	Battery Replacement
Maintenance and	44	Troubleshooting
Troubleshooting	46	Tips to Obtain Optimal Audio Performance
SECTION 6:	47	Warranty Statement
Warranty, Safety and	48	Safety Warnings and Certifications
Specifications	53	System Specifications

IMPORTANT SAFETY INSTRUCTIONS

1. Read these instructions.
2. Keep these instructions.
3. Heed all warnings.
4. Follow all instructions.
5. Do not use the apparatus near water.
6. Clean only with dry cloth.
7. Do not block any ventilation openings. Install in accordance with the manufacturer's instructions.
8. Do not install near any heat sources such as radiators, heat registers, stoves, or other apparatus (including amplifiers) that produce heat.
9. Do not defeat the safety purpose of the polarized or grounding-type plug. A polarized plug has two blades with one wider than the other. A grounding-type plug has two blades and a third grounding prong. The wide blade or the third prong is provided for your safety. If the provided plug does not fit into your outlet, consult an electrician for replacement of the obsolete outlet.
10. Protect the power cord from being walked on or pinched particularly at plugs, convenience receptacles, and the point where they exit from the apparatus.
11. Only use attachments/ accessories specified by the manufacturer.
12. Use only with a cart, stand, tripod, bracket or table specified by the manufacturer, or sold with the apparatus. When a cart is used, use caution when moving the cart/apparatus combination to avoid injury from tip-over. 
13. Unplug this apparatus during lightning storms or when unused for long periods of time.
14. Refer all servicing to qualified service personnel. Servicing is required when the apparatus has been damaged in any way, such as power-supply cord or plug is damaged, liquid has been spilled or objects have fallen into the apparatus, the apparatus has been exposed to rain or moisture, does not operate normally, or has been dropped.
15. When the mains plug or appliance coupler is used as the disconnect device, it shall remain readily operable.
16. Please keep the unit in a good ventilation environment.
17. WARNING: To reduce the risk of fire or electric shock, do not expose this apparatus to rain or moisture.
18. Apparatus shall not be exposed to dripping or splashing and no objects filled with liquids, such as vases, shall be placed on the apparatus.
19. Warning - battery pack shall not be exposed to excessive heat such as sunshine, fire or the like.

5. Warranty, Safety & Specifications

4. Maintenance & Troubleshooting

3. Optional Accessories

2. Set-Up & Use / Daily Operation

1. Overview

SECTION 1:

OVERVIEW

SYSTEM COMPONENTS AND UNPACKING

The standard configuration of the 955 Access will contain:

955 Access and Power Supply

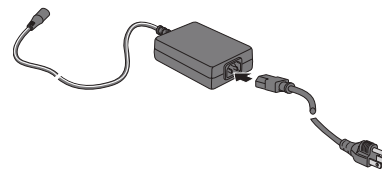

Flexmike Classroom Microphone



Flexmike Cradle Charger & Power Supply



PLEASE NOTE: The 955 Access and any wireless components (microphones, Activate Station, Media Connector, Pods) are registered, or paired, together at the factory and are labeled as such with ID numbers. Please keep all components together as a system. Moving them from one system or room to another will result in the need to re-register them to function.

Additional system labels are attached to the Quick Start Guide should you add components, or if one of your original components should need to be replaced.

SYSTEM COMPONENTS AND UNPACKING CONT'D

Speakers

Systems can be configured with a variety of different speaker types, including the following:

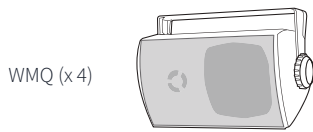
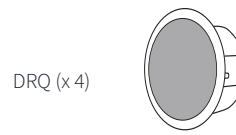
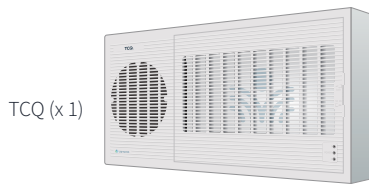

(Available in U.S. and Canada only)

4jCS (x4)
(plenum rated)

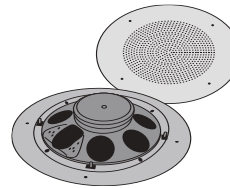

(Available in U.S. only)

5. Warranty, Safety & Specifications

4. Maintenance & Troubleshooting

3. Optional Accessories

2. Set Up & Use / Daily Operation

1. Overview

5. Warranty, Safety & Specifications

4. Maintenance & Troubleshooting

3. Optional Accessories

2. Set Up & Use / Daily Operation

1. Overview
Standard Components U.S. and Canada

955 Access	Wireless audio base station
24V-2.5A-NA	24V/2.5A power supply for 955 Access
FMCC	Transceiver cradle charger, power supply
5V-1.0	5V power supply for FMCC
FM	Flexmike classroom transceiver with battery pack and lanyard
NH2.4V	AA NiMH rechargeable battery pack for Flexmike, one per Flexmike
FL	Flexmike lavalier cord
SPEAKERS	As ordered

Standard Components, outside U.S. and Canada

955-1881	Wireless audio base station
24V-2.5A-__	24V/2.5A power supply for 955 Access, specify country
FMCC-INT	Transceiver cradle charger, power supply
5V-1.0-INT	International 5V power supply for FMCC
FM-1881	Flexmike classroom transceiver with battery pack and lanyard
NH2.4V	AA NiMH rechargeable battery pack for Flexmike, one per Flexmike
FL	Flexmike lavalier cord
SPEAKERS	As ordered

Optional Accessories (U.S. and Canada)

ACT-6P	Activate for small group instruction*
ACT	Activate charging station with Bluetooth
24V-1.75-NA	24V/1.75A power supply for ACT
SM	Sharemike handheld transceiver with battery pack
NH2APK	AA NiMH rechargeable battery pack for Sharemike
USBDC	Charging cable for Sharemike
MCA	Wireless audio transceiver
USB1-NA	MCA power supply
USB-MCB	USB Type A-Micro B power cable for MCA
EMA	Earset microphone with TRRS connector for Flexmike
LMA	Lapel microphone with TRRS connector for Flexmike

Optional Accessories (outside U.S. and Canada)

ACT-6P-1881-__	Activate for small group instruction*, specify country
ACT-1881-__	Activate charging station with Bluetooth, specify country
SM-1881	Sharemike handheld transceiver with battery pack
NH2APK	AA NiMH rechargeable battery pack for Sharemike
USBDC	Charging cable for Sharemike
MCA-1881	Wireless audio transceiver
USB3DC	MCA-1881 power supply
USB-MCB	USB Type A-Micro B power cable for MCA-1881
5V-1.0-INT	5V charging power supply for USB3DC
EMA	Earset microphone with TRRS connector for Flexmike
LMA	Lapel microphone with TRRS connector for Flexmike

OPTIONAL COMPONENTS

Optional equipment which may be part of your system:

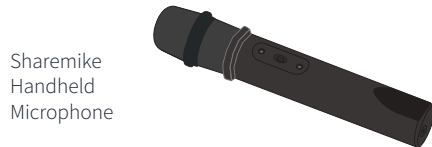

*For further information on Activate for small group instruction, please visit www.lightspeed-tek.com

5. Warranty, Safety & Specifications

4. Maintenance & Troubleshooting

3. Optional Accessories

2. Set Up & Use / Daily Operation

1. Overview

955 FRONT PANEL CONTROLS & INDICATORS

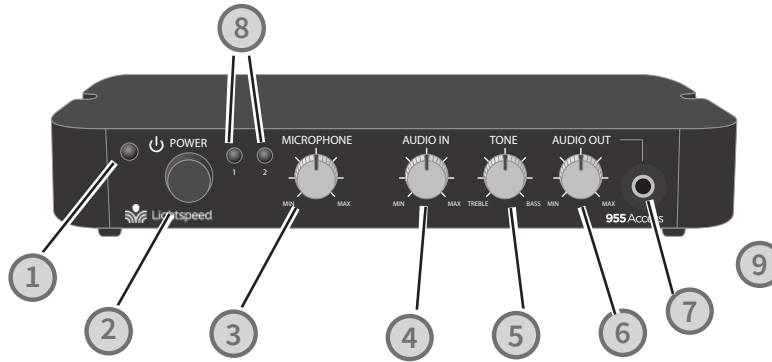

1. **POWER LIGHT:** This light will turn blue when power is on.
2. **POWER BUTTON:** Press and hold this push button to turn the system power on or off.
3. **MICROPHONE VOLUME CONTROL:** Controls the volume level of the microphones.
4. **AUDIO IN VOLUME CONTROL:** Controls the volume level of the audio sources connected to the audio inputs on back of the 955.
5. **TONE CONTROL:** Adjusts the audio tone adding more bass or treble for a more rich or more crisp tone.
6. **AUDIO OUT VOLUME CONTROL:** Controls the volume level of the audio output
7. **AUDIO OUTPUT JACK:** 3.5mm stereo connector for connecting to an assisted listening device (ALD) or to a computer for recording.
8. **MIC 1 & MIC 2:** Microphone link and registration indicators.
 - a. Solid green indicates an audio link has been established.
 - b. Flashing amber indicates registration is in process.
9. **SYSTEM ID LABEL:** On bottom of unit (not shown) to identify it with registered components.

955 REAR PANEL CONTROLS AND CONNECTIONS

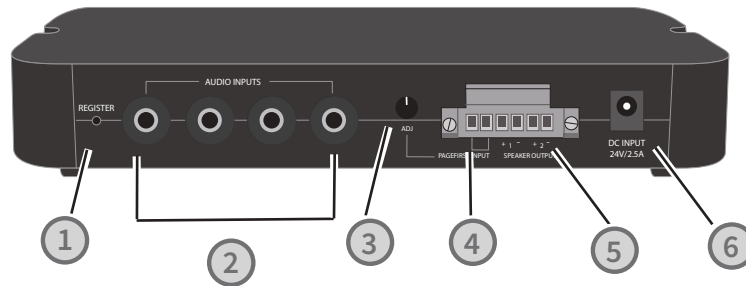

1. **REGISTRATION:** Press this button if there is a new component, such as a microphone, to be registered.
2. **AUDIO INPUTS:** 3.5mm stereo connectors for connecting classroom audio sources to be played through audio system.
3. **PAGING ADJ:** Use the ADJ control to adjust the sensitivity of PageFirst if needed.
4. **PAGEFIRST INPUT:** Connect the input from the optional PageFirst sensor here when interfacing with a building's paging system.
5. **SPEAKER OUTPUTS:** This euro-block connector is used to connect the 955 Access to the loudspeaker(s). Up to two 8-ohm speakers can be connected to each output.
Note: *Wiring to these terminals should follow the Class 2 wiring methods as outlined in the National Electric Code.*
6. **DC POWER:** Plug the power supply (24V/2.5A) into this jack.

5. Warranty, Safety & Specifications

4. Maintenance & Troubleshooting

3. Optional Accessories

2. Set Up & Use / Daily Operation

1. Overview

FLEXMIKE CONTROLS AND CONNECTIONS

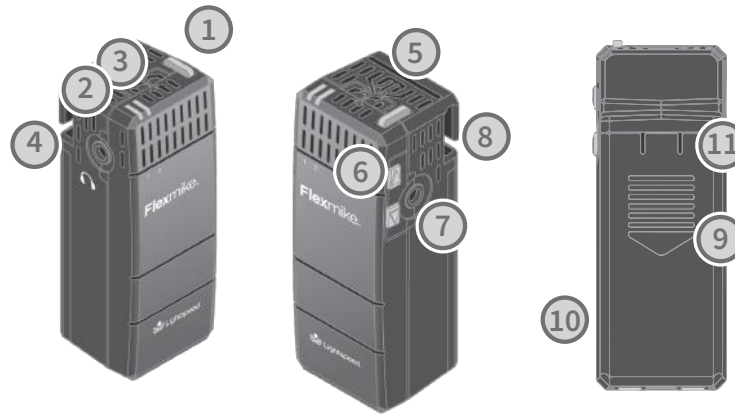

1. **POWER/MUTE SWITCH:** press and hold to power on, press to mute, press and hold to power off.
2. **MIC 1 STATUS:** lighted to indicate microphone is registered as MIC 1
 - **Blue: solid** = normal operation; Blue: flashing = linking in progress
 - **Red: solid** = muted; Red: flashing = muted while linking in progress
3. **MIC 2 STATUS:** when using a second microphone, this LED is lighted to indicate microphone is registered as MIC 2 (same behavior as MIC 1 status light above)
4. **EARBUD/MIC CONNECTION*:** connect the earbud for monitoring for use with Activate Pods only, also for use with optional EMA (earset) and LMA (lapel) microphones.
5. **CHARGING/LOW BATTERY INDICATOR:** lights red when charging, green when fully charged. When in operation, turns red to indicate low battery.
6. **MICROPHONE VOLUME UP/DOWN**
7. **AUDIO INPUT:** connect audio source to send to 955 Access
8. **LANYARD INTERFACE:** insert the lanyard into this hook to wear the Flexmike.
9. **BATTERY DOOR:** remove the battery door to replace the rechargeable battery pack
10. **REGISTRATION:** (inside battery compartment - not shown) only used when adding or replacing Flexmike.
11. **SYSTEM ID LABEL**

FLEXMIKE CRADLE CHARGER



1. **DC POWER PORT:** Connect the 5V/1.0A DC power cord here.
2. **OPTIONAL USB CHARGING PORT:** Plug the charging cord for the optional ShareMike microphone here.

5. Warranty, Safety & Specifications

4. Maintenance & Troubleshooting

3. Optional Accessories

2. Set Up & Use / Daily Operation

1. Overview

CHARGING THE FLEXMIKE

Before use, the Flexmike should be charged. It will take 8-9 hours for the Flexmike to obtain a full charge. A fully charged Flexmike will last for up to 8 hours of use. If microphones are used daily, they should be charged each night.

When properly inserted into a cradle charger, the Mic 1 or Mic 2 light will glow blue and the red light on the Flexmike power button indicates the battery pack is charging. The power button light will glow green to indicate that charging is complete and a full charge has been reached.

Replacement NiMH battery packs may only be purchased through Lightspeed Technologies (part # NH2.4V). Do not attempt to charge with other battery packs. They can overheat and expand creating a significant hazard and damaging the microphone (this is not covered by warranty).

1. Hang the Flexmike on the lanyard opposite the magnetic clasp.
2. Plug power cord into the cradle charger and then plug the AC end into an electrical outlet.
3. Place the Flexmike into the cradle. (Figure 1) The LED on the Flexmike power button will glow red indicating charging has started. The Mic 1 or Mic 2 light will glow blue. (Figure 2)
4. When charging is complete, the power button will glow green.

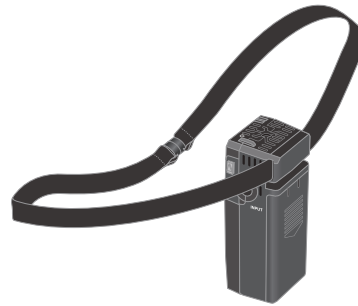

NOTE: If Activate Station was purchased with your system, please refer to page 26 for charging instructions.

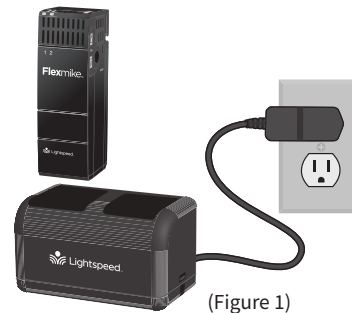

(Figure 1)



(Figure 2)

SECTION 2:

SET-UP & USE/ DAILY OPERATION



5. Warranty, Safety & Specifications

4. Maintenance & Troubleshooting

3. Optional Accessories

**2. Set Up & Use/
Daily Operation**

1. Overview

OPERATING THE FLEXMIKE

Once the Flexmike is charged, follow these steps for use.

1. Remove the Flexmike from the charger and put it on by connecting the magnetic clasps behind your neck. Adjust the lanyard so that the Flexmike is at the top of the collarbone
2. The Flexmike will automatically power on and mute when it is removed from the charger.
3. The microphone volume on the Flexmike is set at the factory to the midpoint.
4. While speaking in a normal voice, fine-tune the microphone volume on the front of the 955 Access up or down. Proper volume level should be as follows:
 - Your voice should be clearly heard by another person on the other side of the room.
 - You should barely be able to hear your own voice.
 - There should not be any audio “feedback” or squealing outside of 2-3 feet (if there is, turn the volume down slightly).



REMEMBER: This equipment supplements the user’s voice so they are able to speak in a conversational tone. Having the volume set too high will result in feedback and listener fatigue.

5. Once initial volume level is set, walk around the room and listen for overall audio quality.
6. If further fine-tuning is required, you may need to adjust the Tone Control on the front of the 955 Access.



USING FLEXMIKE AS WIRELESS AUDIO LINK

The Flexmike includes a 3.5mm audio input jack to connect to an audio source like a laptop or MP3 player. The Flexmike will transmit the audio signal to be played through the system.

If your system includes two Flexmikes, you can use one mic for instruction and the second mic to transmit audio through the system.

1. Plug your external audio equipment (for example, laptop), into the input on the Flexmike labeled "INPUT" using a 3.5mm patch cable (not included).

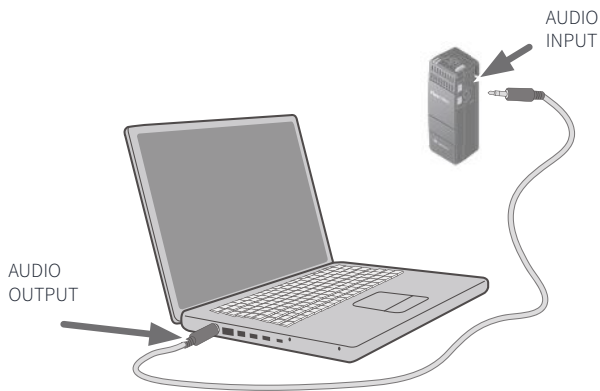

5. Warranty, Safety & Specifications

4. Maintenance & Troubleshooting

3. Optional Accessories

2. Set Up & Use / Daily Operation

1. Overview

OUTPUT TO PERSONAL ASSISTIVE LISTENING DEVICE (ALD)

1. Turn the AUDIO OUT volume control on the front panel all the way down (fully counterclockwise).
2. Determine the size and type of audio input jack on the device as many manufacturers' products differ in connector size and shape. Many Personal FM transmitters require a 3.5 mm to 3.5 mm patch cable (part# MSC3535, not included).
3. Connect a patch cable from the Personal FM's microphone jack or AUX input to AUDIO OUT jack on the front of the 955 Access:

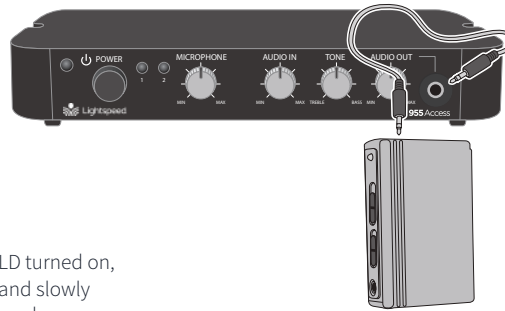
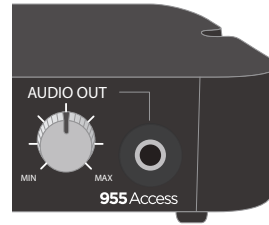

4. With the amplifier and ALD turned on, speak into the Flexmike and slowly adjust the corresponding volume control on the amplifier until the appropriate audio level is obtained in the Personal FM receiver.
5. It may be necessary to adjust the volume on the Personal FM receiver to achieve appropriate volume level.

AUDIO INTEGRATION

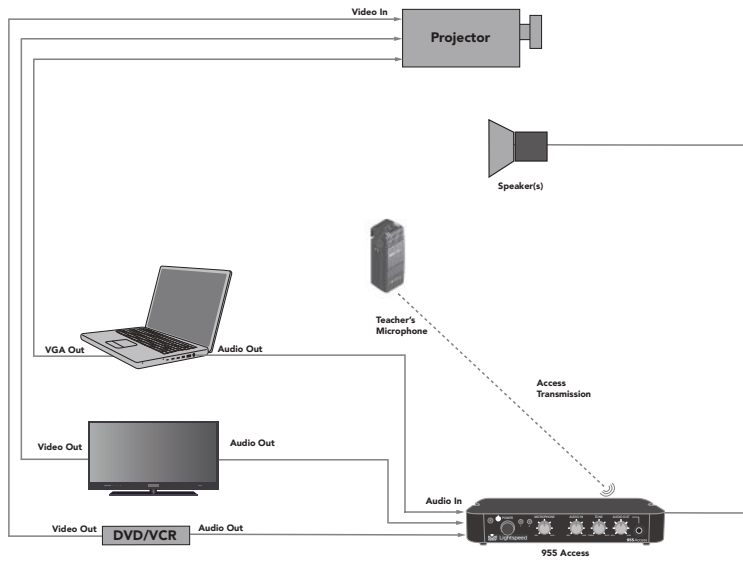

5. Warranty, Safety & Specifications

4. Maintenance & Troubleshooting

3. Optional Accessories

2. Set Up & Use / Daily Operation

1. Overview

DAILY OPERATION INSTRUCTIONS

1. At start of day, remove the microphone from the charger and put on.

- The microphone will default to the Mute position, the status will turn to red.
- Place the microphone around your neck.
- Press the power/mute button, the light will turn blue, indicating the microphone is active and ready to use.
- Adjust volume with the UP/DOWN buttons if necessary.
- If Flexmike needs to be powered down for some time, press and hold the power button. To power Flexmike again, press and hold the power button until the blue light begins to blink.



2. Private conversations.

- Mute the Flexmike during private conversations by momentarily pressing the power button. When muted, the blue light turns red.
- When conversation is over, momentarily press the power button again to unmute the Flexmike.

3. End of day.

- Remove the Flexmike from around your neck.
- Place the Flexmike into the cradle charger and ensure the it is plugged in to an outlet.
- The Flexmike will stay powered on during charging, but will automatically be muted.
- It is not necessary to turn off the 955 Access at end of day, but you may do so by pressing the power button on the front panel.
- If you do want to power it down, when Flexmike is removed from charging the next day, it will automatically power the 955 Access on.



SECTION 3:

OPTIONAL ACCESSORIES

SHAREMIKE CONTROLS & CONNECTIONS

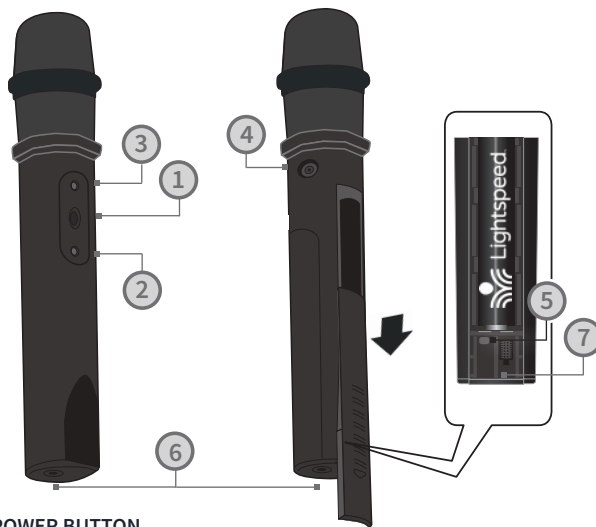

1. POWER BUTTON

2. MIC 2 LIGHT: This light indicates operation status when Sharemike is registered as MIC 2 (Standard)

- **Blue: solid** = normal operation; blinking - link in process
- **Red: solid** = muted

3. MIC 1 LIGHT: This light indicates battery/charging status when Sharemike is registered as MIC 2

- **Red: flashing** = low battery
- **Red: solid** = charging
- **Green: solid** = charging complete

NOTE: The functions of these lights are reversed when a Sharemike is registered as MIC 1.

4. AUDIO INPUT: plug a laptop, MP3 player or other audio device into this jack to wirelessly transmit the audio signal to be played through the system.

5. REGISTRATION BUTTON: Located in the battery compartment, only used when adding or replacing Sharemike.

6. CHARGER INPUT: Plug the charging cable from the Sharemike charger into this jack.

7. SYSTEM ID LABEL

5. Warranty, Safety & Specifications

4. Maintenance & Troubleshooting

3. Optional Accessories

2. Set-Up & Use / Daily Operation

1. Overview

SHAREMIKE: CHARGING

1. Make sure the charger is plugged into a wall outlet. Connect one end of the charging cable into the jack labeled CHARGE on the bottom of the Sharemike.
2. Plug the other end into the USB jack on the back of the cradle charger.
3. If the Sharemike is registered as MIC 2, the MIC 1 light on the microphone will glow red to indicate charging.
4. Leave the Sharemike plugged in overnight (8-10 hours) to obtain a full charge. The light will turn green when charging is complete.
5. If Sharemike is registered as MIC 1, low battery and charging indicator will be the MIC 2 light.
6. During charging the blue light will stay on.



NOTE: If Activate Station was purchased with your system, please refer to page 26 for charging instructions.

PLEASE NOTE: *The 955 Access and microphone(s) are registered, or paired, together at the factory and all components should be kept together as a system. Moving them from one system, or room, to another will result in the need to re-register.*

SHAREMIKE: INITIAL SET-UP

1. Ensure the 955 Access is on. The blue light on the front of the 955 Access will glow.
2. Turn on the Sharemike by pressing and holding the power button until the LED lights.
3. Grip the barrel in the center section.
4. While speaking in a normal voice, increase the volume on the 955 Access MICROPHONE VOLUME knob until your voice is barely audible.

REMEMBER: This equipment is designed to supplement and distribute the user's voice so they are able to speak in a conversational tone. Having the volume set too high will result in feedback and listener fatigue.

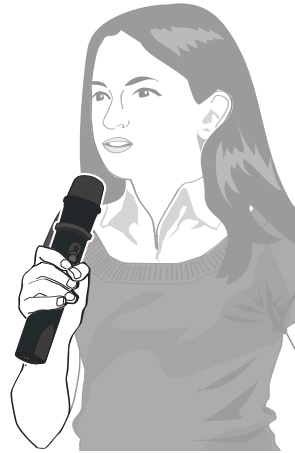

OPTIONAL PAGEFIRST KIT

This optional feature for 955 Access interfaces with an independent classroom paging system. When the page is broadcast, all audio from the system is muted, ensuring important school-wide messages are never missed. Please note that PageFirst is not compatible with telephone or IP-based paging systems.

How it works:

1. PageFirst sensor clip is hung around a lead wire attached to the classroom paging speaker.
2. The clip is hard-wired to the amplifier.
3. As a page is broadcast, the sensor clip detects the audio signal through induction and immediately mutes the amplifier.
4. When the page is over, the audio from the amplifier returns to normal volume level.

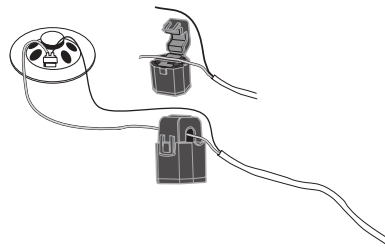

5. Warranty, Safety & Specifications

4. Maintenance & Troubleshooting

3. Optional Accessories

2. Set Up & Use / Daily Operation

1. Overview

ACTIVATE STATION: CONTROLS, CONNECTIONS AND INDICATORS

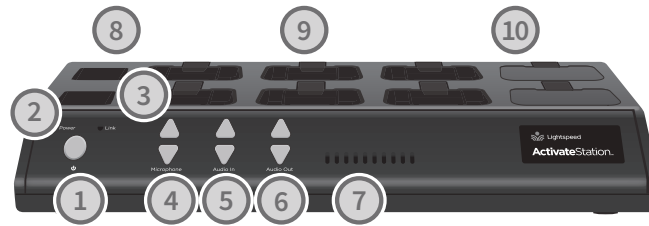

1. **POWER/SLEEP:** press and hold to place the Activate Station and classroom audio system into sleep mode. The Activate Station will continue to charge devices when in sleep mode.
2. **POWER INDICATOR:** the light will turn blue when powered on, amber when placed in sleep mode.
3. **LINK INDICATOR:** this light is solid green to indicate Activate is connected to the audio system and ready for operation. It will blink green for several seconds when initially plugged into power.
4. **MICROPHONE VOLUME:** adjusts the volume level of the classroom speaker for all connected microphones. The indicator lights to the right change to show volume level.
5. **AUDIO INPUT VOLUME:** adjusts the level of multimedia devices plugged into the 3.5mm audio input ports.
6. **AUDIO OUTPUT VOLUME:** adjusts the level of ALD or recording devices plugged into the 3.5mm audio output ports.
7. **VOLUME LEVEL INDICATORS:** shows the volume level of the source that is being adjusted (Microphone, Input, Output). The source level will be updated once a new volume button is pressed.
8. **FLEXMIKE CHARGING SLOTS (2):** place your Flexmike(s) in these slots for nightly charging.
9. **OPTIONAL POD CHARGING SLOTS (8):** place your pods in these slots for nightly charging.
10. **CHARGING COVERS:** covers are included to protect unused pod charging slots from dust and debris.

ACTIVATE STATION: CONTROLS, CONNECTIONS AND INDICATORS, CONT'D



1. **AUDIO INPUTS (1-4):** connect a multimedia audio source to wirelessly send the audio to be played through the whole classroom speaker(s).
2. **AUDIO OUTPUT (ALD):** connect Assistive Listening Device to send the whole classroom audio to an individual student's device.
3. **AUDIO OUTPUT (REC):** connect recording device to capture whole classroom audio from the teachers' microphone. When Record is toggled on in the app, the output provides a fixed level that does not change when the Audio Out volume is adjusted.
4. **BLUETOOTH PAIRING (1-2):** press this button to pair Activate to a mobile device. Download the Lightspeed Activate app from the iOS App Store or Google Play Store for complete instructions.
5. **ACCESS REGISTRATION:** this button is used to pair the Activate Station with the classroom audio system. If purchased together this is done by default at the factory.
6. **USB CHARGE OUTPUTS (PHONE/PODS):** use the first two USB ports to charge a mobile phone or optional additional pods.
7. **USB CHARGE OUTPUTS (PODS/SHAREMIKE):** use these two USB ports to charge optional additional pods or optional Sharemike.
8. **AUX POWER INPUT:** 5V USB power from a laptop or USB power pack can be used in a portable application to power the Activate Station wireless audio functions (in place of the standard 24V power supply). **Note :** Charging is disabled when auxiliary power is used.
9. **DC POWER INPUT:** plug the primary 24V/1.75A power supply into this jack.

5. Warranty, Safety & Specifications

4. Maintenance & Troubleshooting

3. Optional Accessories

2. Set Up & Use / Daily Operation

1. Overview

ACTIVATE STATION: INITIAL SET-UP

DETERMINE SET-UP LOCATION

The Activate Station organizes and charges the pods and microphone(s) and also wirelessly connects audio to the classroom audio system and your mobile device. Set it up in a convenient place near a power source, and that is highly accessible for both teachers and students. If plugging in multimedia audio sources, it should be located in close proximity to minimize cable runs.

Key considerations:

- Close proximity to AC power outlet
- Accessible for daily charging of all components
- Near multimedia audio sources if desired
- Do not place in a fully enclosed metal cabinet

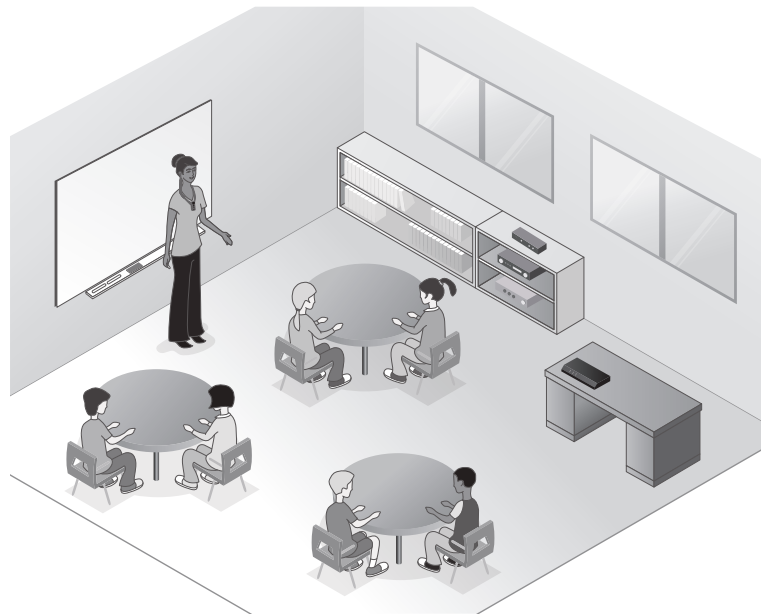

PLUG IN THE ACTIVATE STATION

1. Locate the 24V power supply and power cable.
2. Connect the AC power cord into the DC power supply.
3. Insert the DC connector into the DC Power jack on the back.
4. Plug the AC power cord into an electrical outlet.
5. The blue power light on the front of Activate Station will glow.
6. The green link light will begin blinking as it searches for its paired classroom audio base station (Redcat, Topcat, 955 or Access Link).

Note: If Activate System is being added to an existing Lightspeed audio system, please refer to the Registration Procedure at www.lightspeed-tek.com/accessregistration for proper pairing instructions.

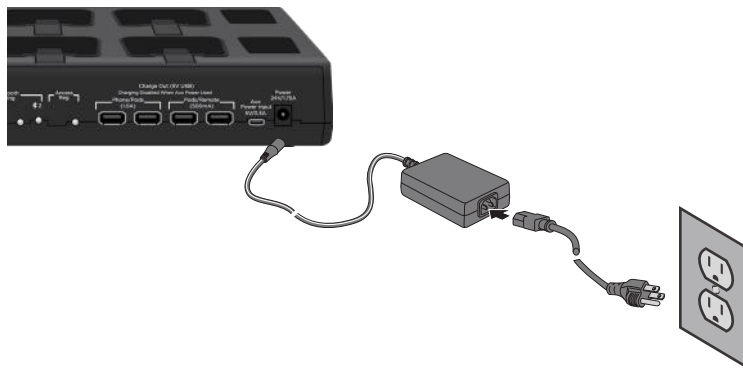

5. Warranty, Safety & Specifications

4. Maintenance & Troubleshooting

3. Optional Accessories

2. Set Up & Use / Daily Operation

1. Overview

PLACE THE FLEXMIKES IN THE ACTIVATE STATION

Prior to full operation, the microphones should be fully charged (at least 8 hours) to ensure optimum performance. In most cases, there should be enough battery life for initial setup and testing.

NOTE: If Activate Station was purchased with your 955 Access, the Activate will be the charger for microphones rather than the FMCC.

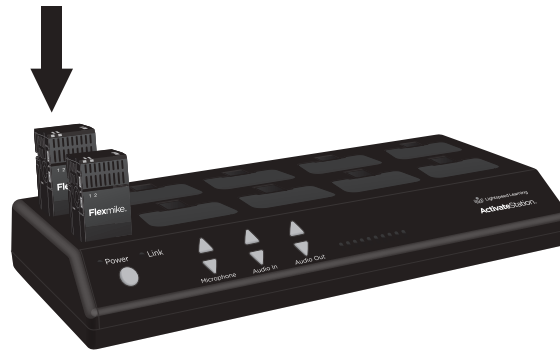

1. Insert the Flexmike(s) into the Activate Station.
2. The Flexmike(s) will power on and the charging light will turn red to indicate normal charging. When fully charged, the charging light will turn green. The blue microphone 1 or 2 light will blink for several seconds as it establishes a link, then turn solid.
3. For systems purchased with optional Sharemikes or handheld remotes, they can be charged by using the USB charging ports on the back of Activate Charging Station.. The charging light will turn red to indicate normal charging. When fully charged, it will turn green.

If your Activate System was purchased together with the 955 Access, all components were registered (paired) together at the factory.

The components are registered and ready for operation when:

- Microphone(s) has a solid blue #1 or #2 light
- Activate Station has a solid green link light

NOTE: When Activate Station is powered on and registered to 955 Access, it locks out Master Volume and Tone controls on the 955 Access.

REGISTER ANY NEW ACTIVATE SYSTEM COMPONENTS

If the Activate Station was purchased separately from the 955 Access system, the Activate will need to be registered (paired) with the 955 for operation.

Please visit the Lightspeed website at www.lightspeed-tek.com/accessregistration to obtain registration instructions.

DOWNLOAD THE MOBILE APP

With your iOS or Android device, visit the App Store or Google Play to download the “Lightspeed Activate” mobile app.



5. Warranty, Safety & Specifications

4. Maintenance & Troubleshooting

3. Optional Accessories

2. Set Up & Use / Daily Operation

1. Overview

5. Warranty, Safety & Specifications

4. Maintenance & Troubleshooting

3. Optional Accessories

2. Set Up & Use / Daily Operation

1. Overview

PAIR YOUR MOBILE DEVICE TO ACTIVATE STATION

You will need to pair your mobile device with Activate Station in order to use it as a remote control. Additionally, you will also need to pair it with Bluetooth in order to play audio from your device through the classroom speaker, as well as be able to record using the App.

1. Turn on Bluetooth in your mobile device. Find and open the Activate App.
2. You will see a set of instructions that will take you through the two pairing processes.
3. Begin by pressing the Bluetooth 1 pairing button on the back of your Activate Station to connect to the 955 Access for remote control functionality. Once paired, any registered pods, if purchased, will appear on the mobile app. - **please note the device name of the connected Activate Station.**
4. You can now pair to Bluetooth audio. The app will take you through a pairing guide and will instruct you to go to your mobile device Settings>Bluetooth. Choose your Activate Station number (ACT_XXXX_BT1) from the list of unpaired devices.
5. Next enter the pin #0000 to complete the pairing process.
6. Press the pair button within the app when prompted. The device should now show as connected.
7. Return to the Activate mobile app. It will take you through a tutorial on how to use the various functions, including some additional functions available only through the app.
8. If there is a second Flexmike for team teaching, repeat the above process with a second mobile device and press the Bluetooth 2 button on the back of the Activate Station.



Bluetooth Pairing

ACTIVATE STATION: OUTPUT TO ASSISTIVE LISTENING DEVICE (ALD)

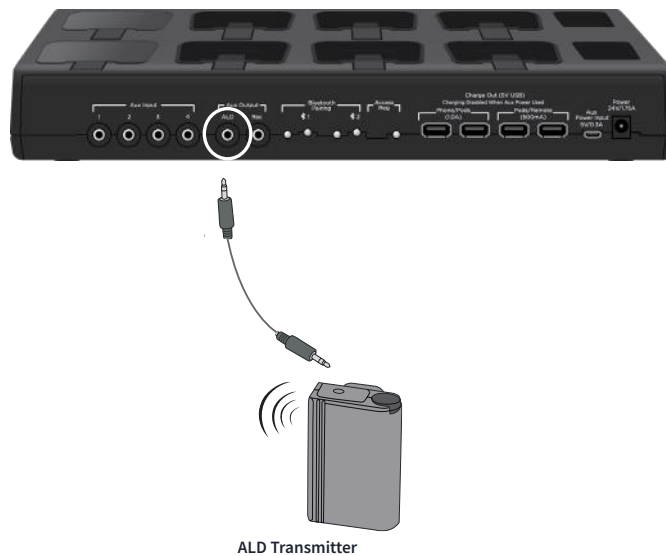

1. Turn the Audio Out volume control on the Activate front panel all the way down.
2. Determine the size and type of audio input jack on the device as many manufacturers' products differ in connector size and shape. Most personal FM transmitters require a 3.5mm to 3.5mm patch cable (part# MSC3535).
3. Connect a patch cable from the ALD's microphone jack or AUX input to the 3.5mm audio jack labeled "ALD" on the back of the Activate.
4. With the 955 and ALD turned on, speak into the Fleximike and slowly adjust the AUDIO OUT volume control on the Activate until the appropriate audio level is attained in the ALD receiver's headphones.
5. It may be necessary to adjust the volume on the Personal FM receiver to achieve appropriate volume level.

5. Warranty, Safety & Specifications

4. Maintenance & Troubleshooting

3. Optional Accessories

2. Set Up & Use / Daily Operation

1. Overview

ACTIVATE STATION: RECORD AND CAPTURE

VIDEO + AUDIO RECORDING

The Activate mobile app allows teachers to utilize their device video camera synced together with the Activate system audio for Lesson Capture and to capture key moments in the classroom. Through the Bluetooth audio link, the App will seamlessly sync up the selected audio source (teacher microphone or Pod) with the video you have recorded.

1. Tap the record tab

- Verify the Bluetooth audio connection is present as indicated by a “headphone” icon in the lower left hand corner of the screen.
- Select Video capture at the top of the screen.

2. Select desired audio source

- Note the selected source indicated in the upper left hand corner of the screen.
- If you wish to change the source, swipe right on the screen to reveal the control arc.
- To record teacher audio only, select the class button. Make sure your microphone is unmuted.
- To record student group audio, select the desired Pod.

NOTE: For optimum student audio quality, the teacher microphone should be muted.

3. Select front or rear camera

4. Begin recording

- Tap the red record button to begin the video recording.
- To pause the video recording, tap the pause button.
- To end the recording, press the stop button.
- To capture a still photo during the recording, tap the white shutter button
- You will see the last recorded video appear as a thumbnail for quick review.

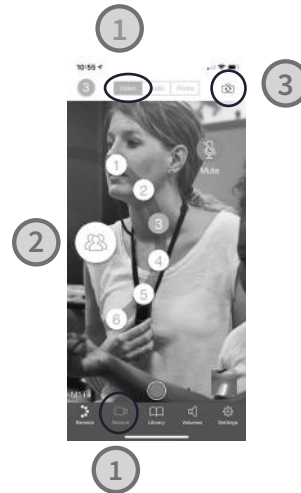

AUDIO ONLY RECORDING

In addition to video recording, teachers can record just the audio of a lesson student interaction.

1. Tap the record tab

- Verify the Bluetooth audio connection is present as indicated by a “headphone” icon in the lower left hand corner.
- Select Audio at the top of the screen.



2. Select desired audio source

- Note the selected source indicated in the upper left hand corner of the screen.
 - If you wish to change the source, swipe right to reveal the control arc.
 - To record teacher audio only, select the class button. Make sure your microphone is unmuted.
 - For student audio, select the desired Pod.
- NOTE:** For optimum student audio quality, mute the teacher microphone.

3. Begin recording

- Tap the red record button to begin the audio recording.
- To capture a still photo during the recording, tap the white shutter button
- To end the recording, press the stop button.
- You will see the last recorded audio file appear as a thumbnail for quick review.



5. Warranty, Safety & Specifications

4. Maintenance & Troubleshooting

3. Optional Accessories

2. Set Up & Use / Daily Operation

1. Overview

3. REMOTE RECORDING

Remote recording allows the teacher to use his/her primary mobile device to start a recording on a secondary mobile device (on a tripod in the front of the classroom for example). During remote recording, the teacher can select pods or class as normal while the secondary device is capturing video synced with that selected audio.

1. Pair two mobile devices to the Activate Station. One as BT1 and the other as BT2.

2. On the teacher's primary device, enable remote recording. This device will become the "controller".

- To enable remote recording, toggle it to the ON position in the settings tab.

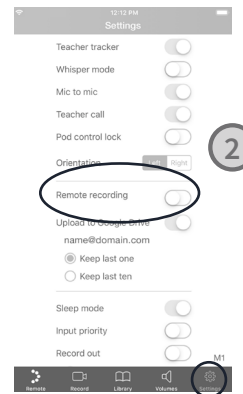

3. Setup the two mobile devices to record

- To set up the mobile device as the controller, tap the white "Remote Record" icon on the video recording preview. This will disable the video camera on the device and show the arc along with the record button which you can press when ready.
- With the controller device set up to begin your recording, set the second mobile device to capture the video for your recording.

4. Begin recording

- Tap the red record button on the controller device to begin the video recording.
- To pause the video recording, tap the pause button.
- To end the recording, press the stop button.
- You will see the last recorded video appear as a thumbnail for quick review on the mobile device acting as your camera.



RECORDING LIBRARY AND PLAYBACK

All of your captured video, audio and photo files are organized and stored in the library tab for easy review.

1. Tap the Library tab

- Select from video, audio or photo library at the top of the screen



2. Tap the desired file to begin playback

- Press the play button at the bottom of the screen and adjust volume on your mobile device as desired.
- Play back audio will default to the teacher earbud.
- To direct the audio to the class speaker, swipe right on the screen to reveal the control arc.
- Select the class speaker, and unmute the microphone.

1

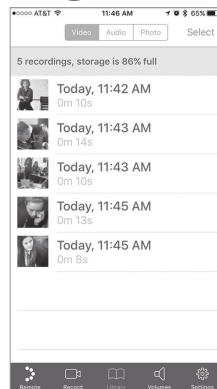

3. Deleting files Edit library and sharing

- Tap the select button and select the desired files to delete.
- Press the trash icon to delete.

4. To send files to another destination

- Tap the select button and select the desired files to send
- Tap the upload icon on the bottom left of the screen
- Select from the menu on your mobile device where you want to send the file(s) - send via SMS or email, share on social media, send to cloud storage server, etc.

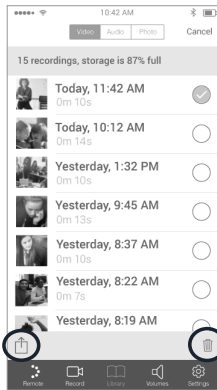

5. Warranty, Safety & Specifications

4. Maintenance & Troubleshooting

3. Optional Accessories

2. Set Up & Use / Daily Operation

1. Overview

5. Automatic file upload to Google Drive

- It is possible to automatically upload files to Google Drive by choosing 'Upload to Google Drive' in the App settings.
- When connected to Google Drive, files will automatically upload.
- Files marked with a check-mark indicate successful upload to Google Drive and are available for viewing, sharing, and collaborating.

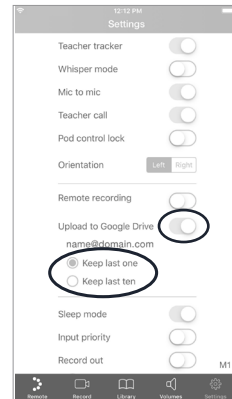

6. Integrate with Google Drive account

- Toggle Upload to Google Drive on.
- You will be directed to link to your google account.
- All files will be automatically uploaded to a new folder into your Google Drive account.
- By default, the last recorded file will be locally stored on your device. All others will be overwritten to preserve storage space.
- In your settings, choose whether you would like to automatically keep the last one recording or the last 10 recordings.

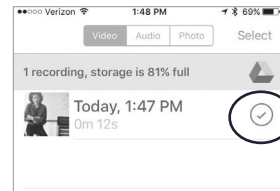

PHOTO CAPTURE

Teachers can also snap still photos of their students to capture student interaction and classroom activities.

1. Tap the record tab

- Select Photo capture at the top of the screen.

2. Capture Photos

- Tap the white photo button to capture an image
- You will see the last photo file appear as a thumbnail for quick review.

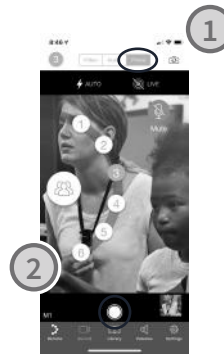

ADDITIONAL CAPABILITIES AVAILABLE WITH ACTIVATE APP

Additional volume adjustments:

On the Volume tab, the teacher can adjust headphone volume, Microphone #1 and #2 volume, volume level on the 955 Access audio input, and Activate Audio In and Out.

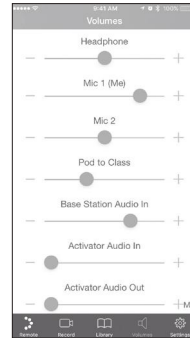

Enable Sleep mode (1):

Your 955 Access comes with sleep mode disabled by default, keeping it powered on and operable at all times. To engage sleep mode, toggle it to the ON position in the settings tab. The 955 Access will go into sleep (low power) mode after 2 hours of no activity. Wake the system back up by un-muting a microphone.

Input priority (2):

Turning this feature on gives all priority to an audio source connected to the amplifier audio input. When an audio signal is detected, all other audio coming through the amplifier (including both microphones) will be muted until the audio input signal ends. Microphone audio will then automatically come back.

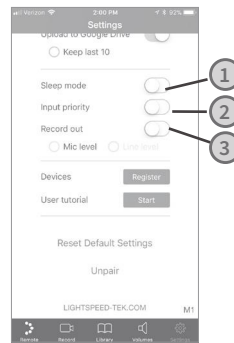

Record out (3):

This allows users to set up REC Output as a fixed level recording output to connect to an external video camera.

- When toggled on, this output will provide a fixed level of audio from the teachers microphone(s) when class speaker is selected. This audio level is not effected by adjustments to the Audio Out volume. Select Mic or Line level signal depending on the recording device.
- When toggled off, this output will provide a variable level output from the classroom speaker. To adjust the level, press the Audio Out Volume buttons on the front panel. Use this setting when interfacing with ALD.

Reset Default Settings:

Pressing this will return the Activate App to its original settings, including volume levels.

Unpair:

Press this button to unpair your mobile device from the Activate system. This is useful if you wish to take your device to pair up with a system next door.

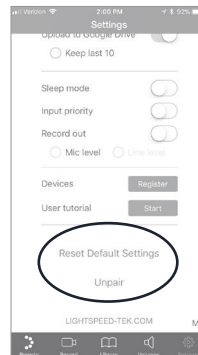

5. Warranty, Safety & Specifications

4. Maintenance & Troubleshooting

3. Optional Accessories

2. Set Up & Use / Daily Operation

1. Overview

5. Warranty, Safety & Specifications

4. Maintenance & Troubleshooting

3. Optional Accessories

2. Set Up & Use / Daily Operation

1. Overview

ACTIVATE STATION: OPTIONAL AUDIO INTEGRATION

The Activate Station is designed to integrate with the 955 and multiple audio sources, allowing other instructional technologies to be clearly heard throughout the classroom.

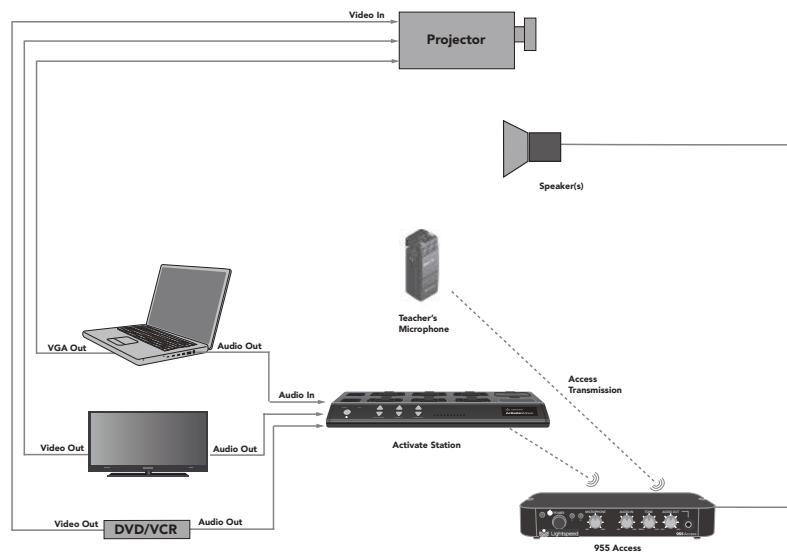

ACTIVATE WITH PODS FOR SMALL GROUP INSTRUCTION

Activate with Pods is a two-way communication system that can be seamlessly added to the 955 Access classroom audio system to foster and facilitate small group instruction. With the small group audio pods and Activate app, Activate opens up communication and interaction between the teacher and student groups, including:

- Teacher monitoring of individual small groups
- Direct instruction to each independent group
- Student group sharing with the whole class
- Reinforce and redirect group activities
- Capture audio and video of student groups or of individual speaker

If your 955 Access system was configured with Activate pods, please refer to the Activate user guide for operation and setup instructions.

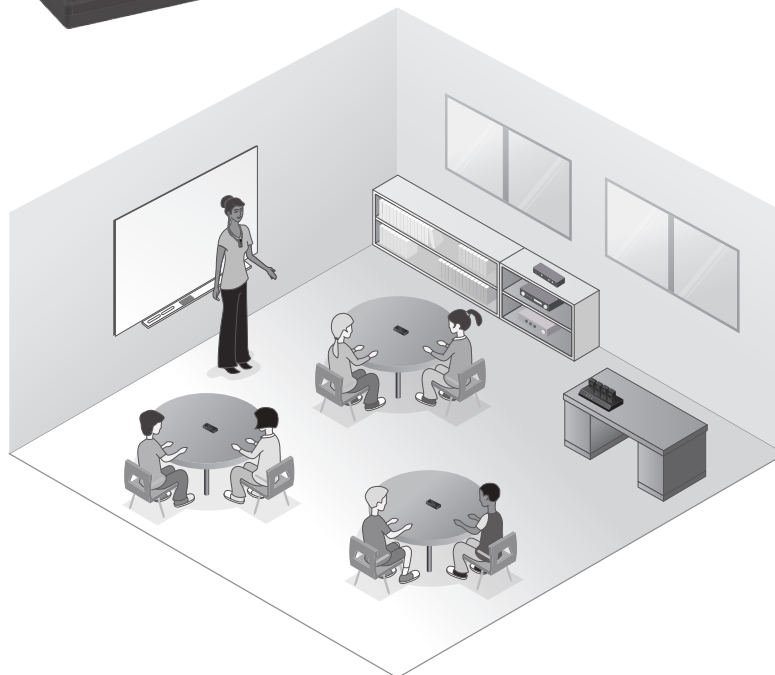

5. Warranty, Safety & Specifications

4. Maintenance & Troubleshooting

3. Optional Accessories

2. Set Up & Use / Daily Operation

1. Overview

MEDIA CONNECTOR CONTROLS AND CONNECTIONS

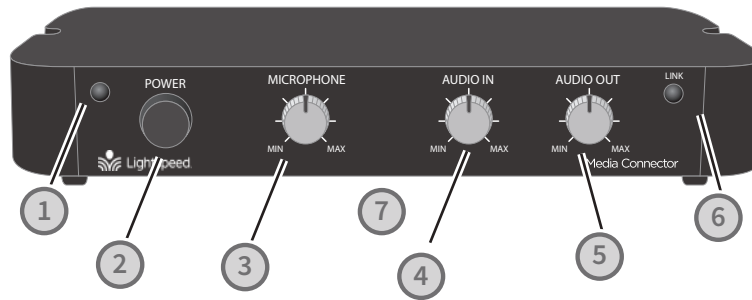

1. **POWER LIGHT:** This light will turn blue when power is on.
2. **POWER BUTTON:** Press and hold this pushbutton to turn the system power on or off.
3. **MICROPHONE VOLUME CONTROL:** Controls the volume level of the microphones.
4. **AUDIO IN VOLUME CONTROL:** Controls the volume level of the connected audio sources.
5. **AUDIO OUT VOLUME CONTROL:** Adjusts the audio signal level output through the ALD audio output connector.
6. **AUDIO LINK LIGHT:** The green light blinks when a link is being established. The light is solid green when the link is established.
7. **SYSTEM ID LABEL:** On bottom of unit

MEDIA CONNECTOR CONTROLS AND CONNECTIONS CONT'D

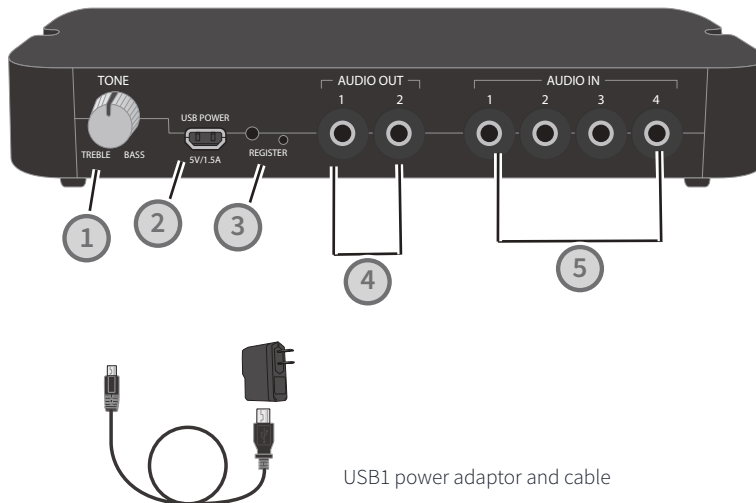

1. **TONE CONTROL:** Adjusts the audio tone, adding more bass or treble for a more rich or crisp sound.
2. **USB POWER INPUT:** Plug the micro USB end of the power cable into this USB port.
3. **REGISTRATION PUSHBUTTON & LIGHT:** Pushing the registration button in conjunction with the registration button on the 955 Access will cause the two units to synchronize as an operating system. The registration light stops blinking and the link light is solid when a link is established. This is only used when adding or replacing a Media Connector.
4. **TWO AUDIO OUTPUTS:** 3.5mm stereo jacks send audio signal to external equipment such as a recorder or an assistive listening device.
5. **FOUR AUDIO INPUTS:** Connect standard audio devices to any of the 3.5mm stereo inputs.

5. Warranty, Safety & Specifications

4. Maintenance & Troubleshooting

3. Optional Accessories

2. Set Up & Use / Daily Operation

1. Overview

INITIAL SET-UP: MEDIA CONNECTOR

DETERMINE SET-UP LOCATION

Choose a location for the Media Connector that is convenient to the classroom audio sources and power supply.

The Media Connector can be placed on a counter or wall mounted. Determine the best location for your room. Use the guidelines below when selecting the site.

NOTE: The Media Connector does not require a direct line of sight to the Topcat. However it functions best when no obstructions are between the two devices. Do not place in an enclosed metal cabinet.

A. Counter or desktop

3-6 feet off of the floor to allow for good transmission.

- Not enclosed in a metal cabinet or otherwise obstructed.

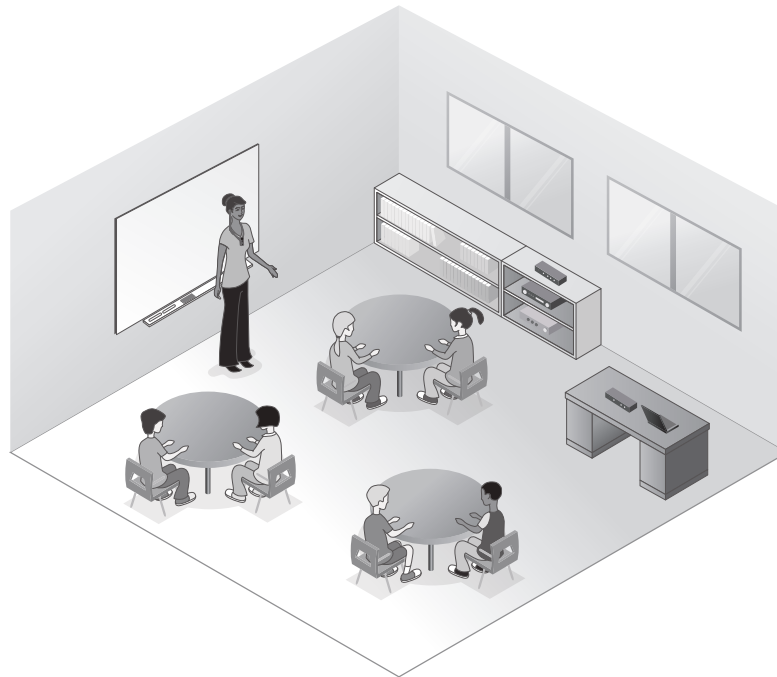

USING THE MEDIA CONNECTOR

The Media Connector can be used as the primary volume control for the audio sources you've connected.

1. Plug the micro USB end of the power cable into the USB port on the back of the Media Connector. Plug the other end of the cable into the USB power adaptor. Also, the USB cable could be plugged into a computer for power.
2. Connect the audio source(s) to the Media Connector using the 3.5mm cables provided.
3. Set the audio source volume to provide sound through the 955 Access.
4. Use the AUDIO IN volume control on the front of the Media Connector to increase or decrease the audio source sound level.

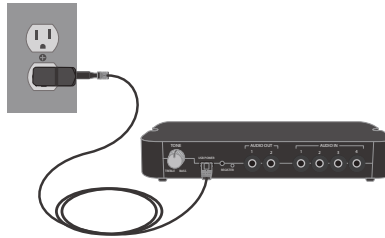

NOTE: When Media Connector is powered on and registered to 955 Access, it locks out Master Volume and Tone controls on the 955 Access.

NORMALIZING AUDIO SOURCE VOLUME LEVELS

Use the Media Connector as the master audio volume control for the classroom. When two or more audio sources are connected, you will need to normalize volume settings by setting all connected audio sources to the same sound level while leaving the Media Connector AUDIO IN volume control set to its center setting. The Media Connector is an audio mixer using a master volume control to adjust the volume of all audio sources at once. Use the following procedure to set audio source volumes:

1. Connect the multimedia audio sources to the Media Connector using the 3.5mm cables provided.
2. Set the AUDIO IN volume control on the Media Connector to its center position.
3. Turn on an audio source that does not have an accessible audio level control. (DVD, VCR player)
4. Adjust the Media Connector AUDIO IN volume control so the audio level playing through the speaker is appropriate for the classroom.
5. Turn off the first audio source.
6. Turn on the second audio source. Use its volume control to balance the audio output to the same audio level played through the speaker as the first source.
7. Repeat steps 5 and 6 for the remaining audio sources.
8. Now, the Media Connector's AUDIO IN volume can be used to increase or decrease the volume level for all audio sources as desired.

5. Warranty, Safety & Specifications

4. Maintenance & Troubleshooting

3. Optional Accessories

2. Set Up & Use / Daily Operation

1. Overview

5. Warranty, Safety & Specifications

4. Maintenance & Troubleshooting

3. Optional Accessories

2. Set Up & Use / Daily Operation

1. Overview

MEDIA CONNECTION: OPTIONAL AUDIO INTEGRATION

The MCA is designed to integrate with the 955 Access and multiple audio sources, allowing other instructional technologies to be clearly heard throughout the classroom.

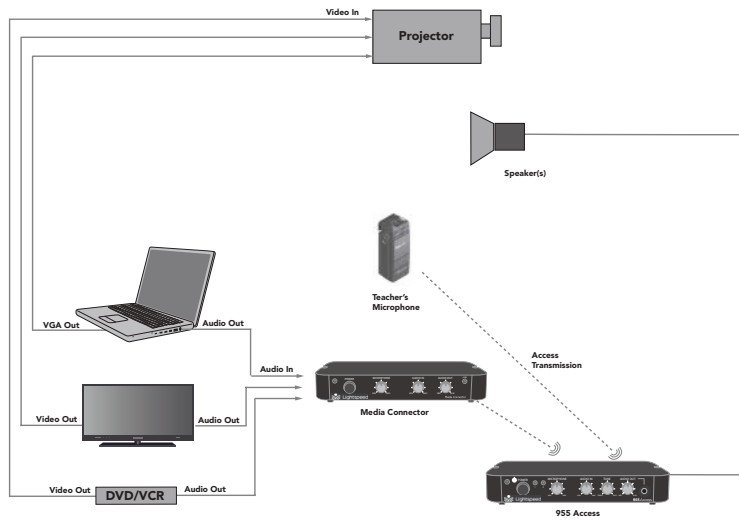

OTHER OPTIONAL ACCESSORIES

EMA	Noise-canceling earset microphone for Flexmike
LMA	Lapel microphone for Flexmike
MSC3535	3.5mm to 3.5mm stereo audio cable
PFSC50	PageFirst Sensor Clip with speaker wire

SECTION 4:

MAINTENANCE & TROUBLESHOOTING

BATTERY REPLACEMENT

Replacement of battery pack in Flexmike.
(Part # NH2.4V)

1. Slide the battery door open.
2. Carefully pull the battery pack away from the Flexmike and disconnect the cable.



3. Connect the cable of the new battery pack as shown and insert the battery pack into the compartment.
4. Slide the cover back on and snap into place.
5. Place the Flexmike in a cradle charger to charge the battery pack.

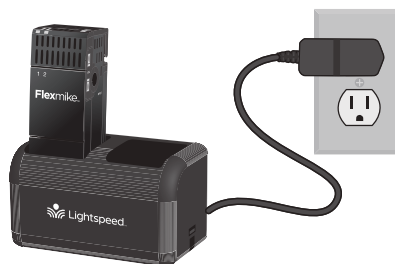

5. Warranty, Safety & Specifications

4. Maintenance & Troubleshooting

3. Optional Accessories

2. Set Up & Use / Daily Operation

1. Overview

BATTERY REPLACEMENT, CONT'D

Replacement of battery pack in Sharemike. (Part # NH2APK)

1. Slide the battery door open.
2. Carefully remove the battery pack from the Sharemike.
3. Insert the new battery pack into the compartment. Ensure proper polarity is observed.
4. Slide the cover back on and snap into place.
5. Connect the Sharemike to a charging cable and plug into the back of the cradle charger to charge the battery pack.



Please dispose of all batteries properly. Lightspeed provides battery recycling at no charge. Contact us at 800-732-8999 for details. Available in U.S. only. Customers outside the U.S. should contact their local reseller.

TROUBLESHOOTING

Note: Most problems are directly related to low battery power. Please run through the “Battery Check” items first. For remaining troubleshooting, use known good, fully-charged batteries.

PROBLEM: Most Problems are related to low battery power.

SOLUTION: Battery Check

- Confirm batteries are charged each night. A blinking red light on the power button indicates a low battery.
- Confirm proper batteries are used. The Flexmike requires the Lightspeed NH2.4V rechargeable battery pack. The Sharemike requires the Lightspeed BA-NH2APK rechargeable battery pack.
- Make sure the microphones obtain a full charge. A full charge takes 8-9 hours.
- When charging the transmitter, ensure the blue status light and the red charging light turn on. The green light will turn on when a full charge is reached.

PROBLEM: Microphone doesn’t indicate a “Ready” signal (solid blue or red light)

SOLUTION: Follow these steps to ensure the system is ready to use.

- Ensure the power button on the microphone is turned on. Once turned on, the blue light should begin blinking.
- Power the microphone off, then on again after a few seconds. Wait for up to 30 seconds for the blue light to turn solid, indicating READY for operation.

PROBLEM: Low Volume or Feedback

SOLUTION: Follow these steps to eliminate low volume or feedback.

- Check microphone volume level on the 955 Access. If the volume is too high, feedback will occur. Adjust accordingly.
- Check input volume level on the 955 Access. If the volume is too high, feedback will occur. Adjust accordingly.
- Adjust the volume level on the Flexmike.

PROBLEM: No Sound From speaker and wireless components.

SOLUTION: Follow these steps to produce sound from 955 Access.

- Confirm that the blue POWER light located on the front panel of the 955 Access is on.
- Confirm the microphone is powered on and linked to the 955. The mic 1 status light will be green on the 955 indicating the microphone is linked.
- Confirm that the microphone is turned on. There will be a solid blue light on the top of microphone to indicate it is powered on and ready.
- Confirm that microphone is not muted. A solid red light on the top of microphone will indicate it is muted.
- Check speaker connections on the 955. Make sure the cables are properly connected (see page 9 of this manual or the Installation Guide for more information).

5. Warranty, Safety & Specifications

4. Maintenance & Troubleshooting

3. Optional Accessories

2. Set Up & Use / Daily Operation

1. Overview

TROUBLESHOOTING CONT'D

- Check volume level of the 955 Access. Make sure that the microphone volume level on the 955 is not turned down all the way. Slowly turn up the volume level while talking into the microphone.
- If an Activate Station or Media Connector is registered (paired) with the 955, make sure that the volume level of the Activate or the Media Connector is not turned down all the way. Slowly turn up the volume level while talking into the microphone.

PROBLEM: Activate app shows message “Activate Station is out of range or has no power”:

SOLUTION:

- This indicates the Bluetooth signal between your device and the Activate Station are having trouble communicating, usually due to range between the mobile device and the Activate Station.
- Make sure your mobile device is within 50-100 feet of the Activate Station. Walk up to the Activate and wait several seconds for the app to reconnect.
- If it does not automatically reconnect, try force quitting the app: for IOS, double tap the Home button on your iOS device, then swipe up the Activate app to close it. For Android, launch the Recent Applications menu, scroll to find the Activate app, then swipe the app to the right to quit. Re-open the app and it should connect automatically.

PROBLEM: Activate app shows “No Response from the Classroom Audio System”

SOLUTION:

- This indicates the app is not communicating with the Access amplifier, usually due to loss of communication between the Activate and the amplifier.
- Make sure the Access amplifier is plugged into power and is powered on.
- If it does not automatically reconnect when the amplifier is powered on, try force quitting the app: for IOS, double tap the Home button on your iOS device, then swipe up the Activate app to close it. For Android, launch the Recent Applications menu, scroll to find the Activate app, then swipe the app to the right to quit. Re-open the app and it should connect automatically.

If you review these instructions and still have questions, call Lightspeed Technical Services at 800.732.8999, 5 a.m. – 5 p.m., PST. Customers outside the U.S. should contact their local reseller.

TIPS TO OBTAIN OPTIMUM AUDIO PERFORMANCE

- Speak in a natural voice. A normal conversational speech level will provide an adequate signal. It is not necessary to increase the intensity of your voice—the audio system provides adequate amplification (approximately 5 – 10 dB) above ambient room noises.
- Avoid wearing jewelry that may rub or bump against the microphone.
- Mute the Flexmike during private conversations with a student, parent, or other classroom visitor. You can tell the mic is muted when the light turns red.
- Recharge microphones each night. When recharged nightly, operating time (actual usage) for the microphones will last through a typical school day.

5. Warranty, Safety & Specifications

4. Maintenance & Troubleshooting

3. Optional Accessories

2. Set Up & Use / Daily Operation

1. Overview

SECTION 5:

WARRANTY, SAFETY & SPECIFICATIONS

FIVE-YEAR LIMITED WARRANTY

Lightspeed Classroom Audio Access Systems are guaranteed against malfunction due to defects in materials and workmanship for a period of FIVE (5) YEARS, beginning at the date of the purchase invoice. If such malfunction occurs, the product will be repaired or replaced (at Lightspeed's option) without charge during the warranty period.

Lightspeed's Warranty Exchange Program applies to all classroom audio systems within the five (5) year warranty period. If a classroom audio product or component has an issue that requires service, a refurbished replacement will immediately be sent to the customer to minimize downtime. Customers will receive the exchange product(s) or component(s) within 2-3 days. A prepaid return label will be included with exchanged products so original malfunctioned equipment can be returned to Lightspeed. Any exchanged equipment will remain covered under the original five (5) year warranty.

1. Warranty on Access transceivers is FIVE (5) YEARS.
2. Warranty on Lightspeed NiMH rechargeable batteries is one (1) year.
3. A prepaid shipping label will be provided by Lightspeed for warranty repairs within the United States. Customers outside the U.S. should refer to the Lightspeed website (www.lightspeed-tek.com) for warranty repair instructions.
4. Warranty does not extend to finish, appearance items, or malfunctions due to abuse or operation other than specified conditions, nor does it extend to incidental or consequential damages. Repair by other than Lightspeed or its authorized service agencies will void this warranty. Information on authorized service agencies is available from Lightspeed Technologies, Inc.

Our Service Department (800.732.8999, 5 a.m. – 5 p.m., PST) will handle all your repair/replacement needs. Customers outside the U.S. should contact their local reseller.

SAFETY WARNINGS AND CERTIFICATIONS



CAUTION
 RISK OF ELECTRICAL SHOCK
 DO NOT OPEN



THIS PRODUCT MUST BE INSTALLED IN ACCORDANCE WITH THE APPLICABLE INSTALLATION CODE BY A PERSON FAMILIAR WITH THE CONSTRUCTION AND OPERATION OF THE PRODUCT AND THE HAZARDS INVOLVED.



The lightning flash with arrowhead symbol inside an equilateral triangle is intended to alert the user to the presence of non insulated "hazardous voltage" within the product's enclosure, which may be of sufficient magnitude to induce a risk of electric shock to persons.



The exclamation mark inside an equilateral triangle is intended to alert the user to the presence of important operating and maintenance (servicing) instruction in the literature accompanying this product.



USE A LIGHTSPEED SUPPLIED BATTERY ONLY

CERTIFICATIONS



This product is listed to UL standards and requirements for electrical safety by Underwriters Laboratories Inc.



This product conforms with the essential requirements of the following European Union Directives: 2004/108/EC Electromagnetic Compatibility (EMC) and 2006/95/EC Low Voltage Directive (LVD).



Lightspeed Technologies launched a formal product recycle program in Europe that complies with the European Union Directive 2002/96/EC on Waste Electrical and Electronic Equipment ("WEEE Directive"). Please visit our website at www.Lightspeed-tek.com for more information.



This product is manufactured using lead-free processes and is free of other materials harmful to the environment. It conforms to the most stringent new European guidelines for consumer products (RoHS).

5. Warranty, Safety & Specifications

4. Maintenance & Troubleshooting

3. Optional Accessories

2. Set Up & Use / Daily Operation

1. Overview

PRÉCAUTIONS DE SÉCURITÉ ET CERTIFICATIONS



ATTENTION
RISQUE D'ÉLECTROCUTION
NE PAS OUVRIR



CONFORMÉMENT AUX NORMES D'INSTALLATION APPLICABLES, CE PRODUIT DOIT ÊTRE INSTALLÉ PAR UNE PERSONNE FAMILIARISÉE AVEC LA CONCEPTION ET LE FONCTIONNEMENT DU PRODUIT ET CONSCIENTE DES RISQUE ENCOURUS.



L'éclair flèche dans un triangle équilatéral avertit l'utilisateur de la présence d'une "tension dangereuse" non isolée à l'intérieur de l'appareil, qui peut être d'une ampleur suffisante pour constituer un risque d'électrocution.



Le point d'exclamation contenu dans un triangle équilatéral avertit l'utilisateur de la présence d'importantes instructions d'exploitation et de maintenance dans la documentation qui accompagne ce produit.



UTILISEZ UNIQUEMENT LA BATTERIE LIGHTSPEED FOURNIE

CERTIFICATIONS



Ce produit est certifié conforme aux normes et aux exigences UL en matière de sécurité électrique par Underwriters Laboratories Inc.



Ce produit est conforme aux principales exigences des directives de l'Union Européenne suivantes : 2004/108/EC Electromagnetic Compatibility (EMC) and 2006/95/EC Low Voltage Directive (LVD).



Lightspeed Technologies a lancé un programme de recyclage de produits en Europe conformément à la directive de l'Union Européenne 2002/96/CE relative aux déchets d'équipements électriques et électroniques (directive « DEEE »). Veuillez visiter notre page Web www.Lightspeed-tek.com pour plus de renseignements.



Ce produit est fabriqué en utilisant des processus sans plomb ni aucune autre matière nuisible à l'environnement. Il est conforme aux nouvelles règles européennes les plus strictes en matière de biens de consommation (RoHS).

FCC Notice to user

This device complies with Part 15 of the FCC Rules. Operation is subject to the following two conditions:

- (1) This device may not cause harmful interference; and
- (2) This device must accept any interference received, including interference that may cause undesired operation.

This equipment has been tested and found to comply with the limits for a Class B digital device, pursuant to Part 15 of the FCC Rules. These limits are designed to provide reasonable protection against harmful interference in a residential installation.

This equipment generates, uses, and can radiate radio frequency energy and, if not installed and used in accordance with the instructions, may cause harmful interference to radio communications. However, there is no guarantee that interference will not occur in a particular installation.

If this equipment does cause harmful interference to radio or television reception, which can be determined by turning the equipment off and on, the user is encouraged to try to correct the interference by one or more of the following measures:

- Reorient or relocate the receiving antenna (that is, the antenna for radio or television that is receiving the interference).
- Reorient or relocate and increase the separation between the telecommunications equipment and receiving antenna.
- Connect the telecommunications equipment into an outlet on a circuit different from that to which the receiving antenna is connected.
- Consult the dealer or an experienced radio/TV technician for help.

English:

IMPORTANT NOTE: To comply with the FCC RF exposure compliance requirements, the antenna(s) used for this transmitter must be installed to provide a separation distance of at least 20 cm from all persons and must not be co-located or operating in conjunction with any other antenna or transmitter. No change to the antenna or the device is permitted. Any change to the antenna or the device could result in the device exceeding the RF exposure requirements and void user's authority to operate the device.

French:

NOTE IMPORTANTE: Pour se conformer aux règles d'exposition des ondes RF par la FCC, la (ou les) antenne(s) utilisée(s) par ce transmetteur doivent être installées de façon à être séparée d'une distance d'au moins 20 cm de toute personne et ne doit pas être utilisée près ou en conjonction avec aucune autre antenne ou transmetteur. Aucune modification à l'antenne ou à l'appareil n'est permise. Toute modification à l'antenne ou à l'appareil peut résulter que l'appareil excèdera l'exposition aux ondes RF réglementaires et ainsi annuler le droit à l'utilisateur d'utiliser l'appareil.

FCC RF Radiation Exposure Statement

This device (Access Link) complies with the FCC RF radiation exposure limits set forth for an uncontrolled environment. This device should be installed and operated with a minimum distance of 20cm between the radiator (Access Link) and any part of your body.

For body worn operation, the portable part (Flexmike) has been tested and meets FCC RF exposure guidelines.

This device must not be co-located or operating in conjunction with any other antenna or transmitter. The changes or modifications not expressly approved by the party responsible for compliance could void the user's authority to operate the equipment.

Notice to Canada User

English

This device complies with Industry Canada licence exempt RSS standard(s).

Operation is subject to the following two conditions:

- (1) this device may not cause interference, and
- (2) this device must accept any interference, including interference that may cause undesired operation of the device.

French

Le présent appareil est conforme aux CNR d'Industrie Canada applicables aux appareils radio exempts de licence. L'exploitation est autorisée aux deux conditions suivantes :

- (1) l'appareil ne doit pas produire de brouillage, et
- (2) l'utilisateur de l'appareil doit accepter tout brouillage radioélectrique subi, même si le brouillage est susceptible d'en compromettre le fonctionnement.

5. Warranty, Safety & Specifications

4. Maintenance & Troubleshooting

3. Optional Accessories

2. Set Up & Use / Daily Operation

1. Overview

RF Radiation Exposure Statement

English

Your mobile device is a radio transmitter and receiver. It is designed not to exceed the limits for exposure to radio waves (radio frequency electromagnetic fields) recommended by international guidelines. The guidelines were developed by Health Canada and include a substantial safety margin designed to assure the safety of all persons, regardless of age and health.

French

Votre appareil mobile est un émetteur-récepteur radio. Il est conçu pour ne pas dépasser les limites d'exposition aux ondes radio (champs électromagnétiques de fréquence radio) recommandées par les directives internationales. Les lignes directrices ont été élaborées par Santé Canada et comprennent une marge de sécurité importante destinée à assurer la sécurité de toutes les personnes, indépendamment de l'âge et de la santé.

NOTICE FOR USB

NOTE: Lightspeed is not responsible for any changes or modifications not expressly approved by the party responsible for compliance. Such modifications could void the user's authority to operate the equipment.

NOTE: This equipment has been tested and found to comply with the limits for a Class B digital device, pursuant to part 15 of the FCC Rules. These limits are designed to provide reasonable protection against harmful interference in a residential installation. This equipment generates, uses and can radiate radio frequency energy and, if not installed and used in accordance with the instructions, may cause harmful interference to radio communications. However, there is no guarantee that interference will not occur in a particular installation. If this equipment does cause harmful interference to radio or television reception, which can be determined by turning the equipment off and on, the user is encouraged to try to correct the interference by one or more of the following measures:

- Reorient or relocate the receiving antenna.
- Increase the separation between the equipment and receiver.
- Connect the equipment into an outlet on a circuit different from that to which the receiver is connected.
- Consult the dealer or an experienced radio/TV technician for help.

EU DECLARATION OF CONFORMITY



EU Declaration of Conformity
According to EU Directives EMC 2014/30/EU, LVD 2014/35/EU, RED 2014/53/EU

Manufacturer: Lightspeed Technologies, Inc.

Address: 11509 SW Herman Rd,
Tualatin, Oregon 97062

We herewith declare that the following systems comply with the appropriate basic safety and health requirements of the Directive based on its design and type, as brought into circulation by us. In case of alteration of the system, not agreed upon by us, this declaration will lose its validity.

Products: Redcat Access, Flexmike, Flexcat Pod, Flexcat Charging Station, Flexcat Handheld Remote Control, Media Connector Access, Sharemike, Topcat, Access Link, 955 Access, Activate Station, Activate Pod, TCQ2, DRQ, Mobile Connector

Model Numbers: LSRCA 1881, LSFM 1881, FCP 1881, FCCS, FCHRCB, LSMCA 1881, LSSM 1881, LSTCA 1881, LSAI 1881, LS955 1881, LSACT 1881, LSPOD 1881, TCQ2, DRQ, MCX

As applicable, products conform to the following EU/AS/NZ test standards listed below:

Safety Standards: IEC/EN 60065 and amendments

EMC/RF Standards: EN301 406 V2.1.1 (2009-07)

EN 301489-1/-6
EN 301489-1/-17
EN 50371 (2002)
EN 50385 (2002)
EN 300 328
EN 55022
EN 55024
AS/NZ CISPER 22
AS/NZ 4268

The Technical Construction File is available to proper authorities and the product is CE marked.

Lightspeed Representative:



Michael Frost, Compliance Engineer

Date: December 12, 2018

P/N: 085-0013-07

LIGHTSPEED TECHNOLOGIES / 11509 SW HERMAN ROAD / TUALATIN, OR 97062 / 800.732.8999 / WWW.LIGHTSPEED-TEK.COM

5. Warranty, Safety & Specifications

4. Maintenance & Troubleshooting

3. Optional Accessories

2. Set Up & Use / Daily Operation

1. Overview

SYSTEM SPECIFICATIONS

955 ACCESS

Description:	Wireless audio hub
Frequency response:	60 Hz - 7 kHz
DC power Input:	24V/2.5A
Power output:	40 Watts total (20 W/channel)
Total harmonic distortion:	<1% @ 10W
Wireless communication:	Access Technology (1.9 GHz + RF4CE)
Tone control:	1 bass/treble control
Audio inputs:	Four (4) 3.5mm stereo w/ volume control
Audio output:	3.5mm stereo w/ volume control
PageFirst input:	Euroblock
Audio Link indicators:	2 indicators for Flexmike 1 and 2
Device Registration:	Push button for pod(s), Flexmike(s), Share-mike, Media Connector, and remote(s)
Dimensions (W x H x D):	7.6" x 5" x 1.13" (193 x 127 x 29mm)
Weight:	9.6 oz. (272g)

FLEXMIKE (1-2):

Description:	Pendant-style transceiver
Earbud lanyard:	Magnetic clasp with integrated earbud
Wireless communication:	Access Technology (1.9 GHz)
Audio distortion:	<1%
Integrated microphone:	Uni-directional electret
Earbud output:	3.5mm
Audio input:	3.5mm
Volume control:	+/- 6 dB
Battery power:	2.5V NiMH battery pack
Battery life:	8 hours (fully charged)
Charging:	2 contacts for cradle charging
USB connection:	Type Micro-B for charging and audio
Power:	On/off switch
Registration:	Push button for registration with 955 Access
Dimensions (L x W x H):	2.9" x 1.1" x 1.0" (74 x 28 x 25mm)
Weight:	1.8 oz (51g)

SHAREMIKE

Description:	Handheld transceiver
Wireless communication:	Access Technology (1.9 GHz)
Audio distortion:	<1%
Integrated microphone:	Uni-directional dynamic
Audio input:	3.5mm
Battery power:	2 AA NiMH battery pack
Battery life:	8 hours (fully charged)
Charging:	5V charging jack
Power:	On/off button
Registration:	Push button for registration with 955 Access
Dimensions (L x W x H):	2.25" x 2.25" x 8.75" (57.2 x 57.2 x 222.3mm)
Weight:	7.36 oz (209g)

ACTIVATE CHARGING STATION

Description:	Charging station with Bluetooth
DC power input:	24V / 1.75A
DC charging ports:	4 USB ports for charging pods, remote control or Sharemike
Cradle charging:	8 pods; 2 Flexmikes
USB port:	5V USB charging input for optional power source
Wireless communication:	Bluetooth, Access Technology (1.9 GHz + RF4CE)
Wireless range (from 955 Access amplifier):	up to 200 ft (60 m); up to 100 ft (30 m) with walls
Audio input:	3.5mm stereo (x4) w/ master volume
Audio output:	3.5mm stereo (X2) mixed w/ volume control
Audio Link indicator:	1 LED on front panel
Registration indicator	LED (x3) on back panel
Device Registration:	Push button (x2) for Bluetooth pairing, Push button (x1) for Access pairing
Dimensions (W x H x D):	13.3" x 5.9" x 1.9" (340 x 150.3 x 50mm)
Weight:	1.85 lbs (084kg)

5. Warranty, Safety & Specifications

4. Maintenance & Troubleshooting

3. Optional Accessories

2. Set Up & Use / Daily Operation

1. Overview

MEDIA CONNECTOR

Description:	Wireless audio transceiver
USB Power:	5V micro-B USB connector
Wireless communication:	Access Technology (1.9 GHz + RF4CE)
Tone control:	1 bass/treble control
Audio input:	3.5mm stereo (x4) w/ master volume
Audio output:	3.5mm stereo (X2) mixed w/ volume control
Audio Link indicator:	1 LED on front panel
Registration indicator	1 LED on back panel
Device Registration:	Push button for 955 Access
Dimensions (W x H x D):	7.6" x 5" x 1.13" (193 x 127 x 29mm)
Weight:	9.6 oz. (272g)



Dedicated to Access for all

We strive to make a remarkable difference for teachers and students by creating Access to powerful in-the-moment insights to the learning process. Our audio and video solutions improve student engagement, enable teachers to activate small groups, and encourage collaboration.

11509 SW HERMAN ROAD
TUALATIN, OREGON 97062
TOLL FREE: 800.732.8999
PHONE: 503.684.5538
FAX: 503.684.3197
LIGHTSPEED-TEK.COM

MN0513US01-6

