

Installation Instructions



SoundHouse

**Recess in Cavity.
As an add on to
Music/Performance
Audio Infrastructure by
Others. With additional
microphones**

 **hear and learn**
all audio to all ears. always.



UConnect SoundHouse by hearandlearn.com.au is a bespoke steel cabinet complete with internal electronics, power supplies, labelling and signage for capturing and delivering instructional audio in learning spaces.

There are two versions of the UConnect SoundHouse – our WALL MOUNTED version and our RECESSED version. This document is relevant to installing our RECESSED version which have a right angled rear body for easy install complete with flange. It should not wall mounted.

This configuration of SoundHouse includes our Access Link receiver. Our Flexmike and Sharemike are paired to the Access Link pre installed in the SoundHouse. These microphones are charged and stored in the SoundHouse for convenient usage.

Your RECESSED SoundHouse is equipped with HEARING AUGMENTATION facilities. This means forms of electronic Instructional Audio, PA, Screens – will be connected to the SoundHouse making it available to people in these spaces who have receivers built in their hearing aids.

SOUNDHOUSE IS FOR EVERYDAY USE BY TEACHERS AND LEARNERS, BE UNOBSCURED, HAVE EASY ACCESS AND WITH LINE OF SIGHT OF AREAS OF THE ROOM.

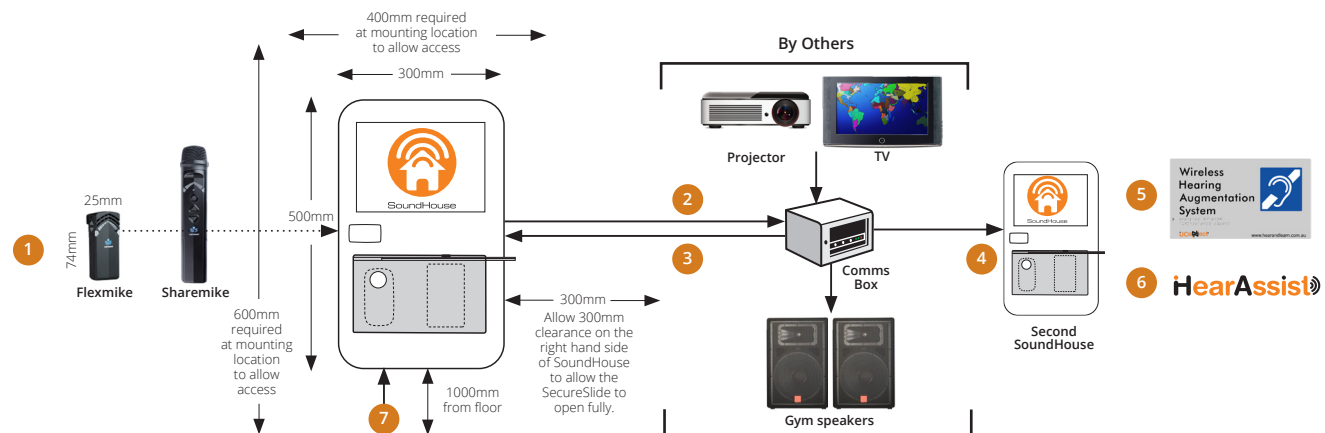

1. Flexmike and Sharemike paired to Access Link inside SoundHouse
2. Output from AccessLink to Comms Box for Music / Performance Audio Infrastructure by Others. If the length of cable from output of AccessLink to Comms Box is less than 10m, use general audio cable with 3.5mm male plug to connect to from Access Link to Comms Box. If length of cable is greater than 10m, use CAT 5E/6 cable with Audio Extenders at each end.
3. Output from Comms Box to Input on ElectroBox inside SoundHouse. If the length of cable from output of Access Link to Comms Box is less than 10m, use general audio cable with 3.5mm male plug to connect to from Access Link to Comms Box. If length of cable is greater than 10m, use CAT 5E/6 cable with Audio Extenders at each end.
4. Depending on the size and configuration of the space, a second SoundHouse may be required. Consult with Hear and Learn.
5. Braille Tactile signs provided by Hear and Learn. They must be mounted to these compulsory rules: The sign must be located not less than 1200 mm and not higher than 1600 mm above the floor or ground surface. Located on the wall on the latch side of the door with the leading edge of the sign located between 50 mm and 300 mm from the architrave. If this is not possible, the sign may be placed on the door itself. **See Page 12.**
6. HearAssist includes local installation assistance, commissioning and staff training.
7. Connection of power to GPO's prebuilt into SoundHouse. No wall GPO(s) required.



See hearandlearn.com.au/hearing-augmentation-solutions

hearandlearn.com.au

UConnect SoundHouse, Mini, 975 POINT-TO-PAIR-3, Redcat POINT-TO-PAIR-3 and Topcat POINT-TO-PAIR-3 are part of the Hear and Learn technology family

Offices Australia wide (03) 9370 9355

Installation Instructions



SoundHouse

Recess in Cavity.
As an add on to
Music/Performance
Audio Infrastructure by
Others. With additional
microphones

The SoundHouse recessed-in-wall model is designed for recessing into a wall cavity.
NOTE: This requires carpentry which stakeholders in this project have been advised about previously.

10mm

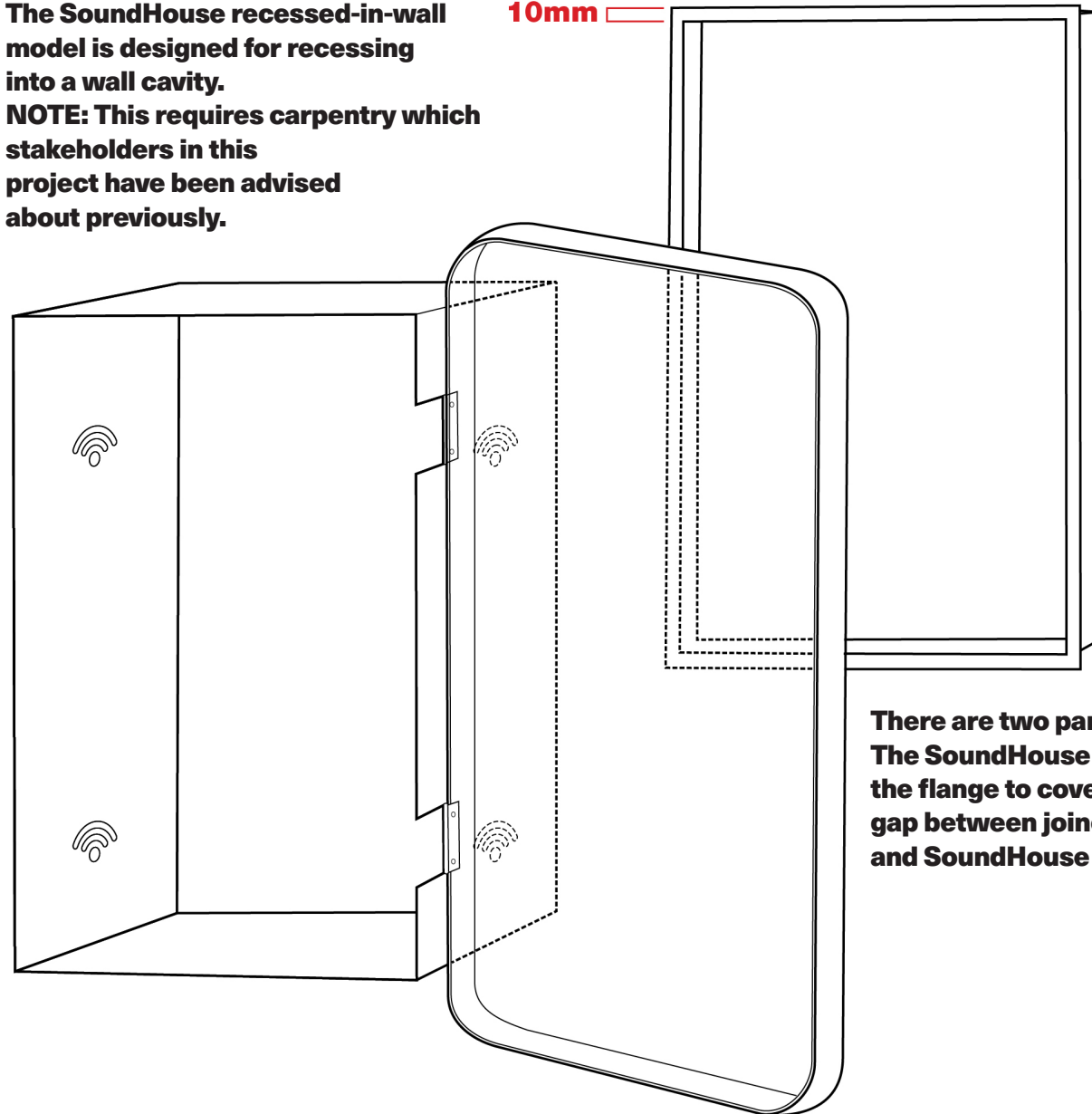

**There are two parts:
The SoundHouse and
the flange to cover the
gap between joinery/wall
and SoundHouse**

Installation Instructions



SoundHouse

**Recess in Cavity.
As an add on to
Music/Performance
Audio Infrastructure by
Others. With additional
microphones**

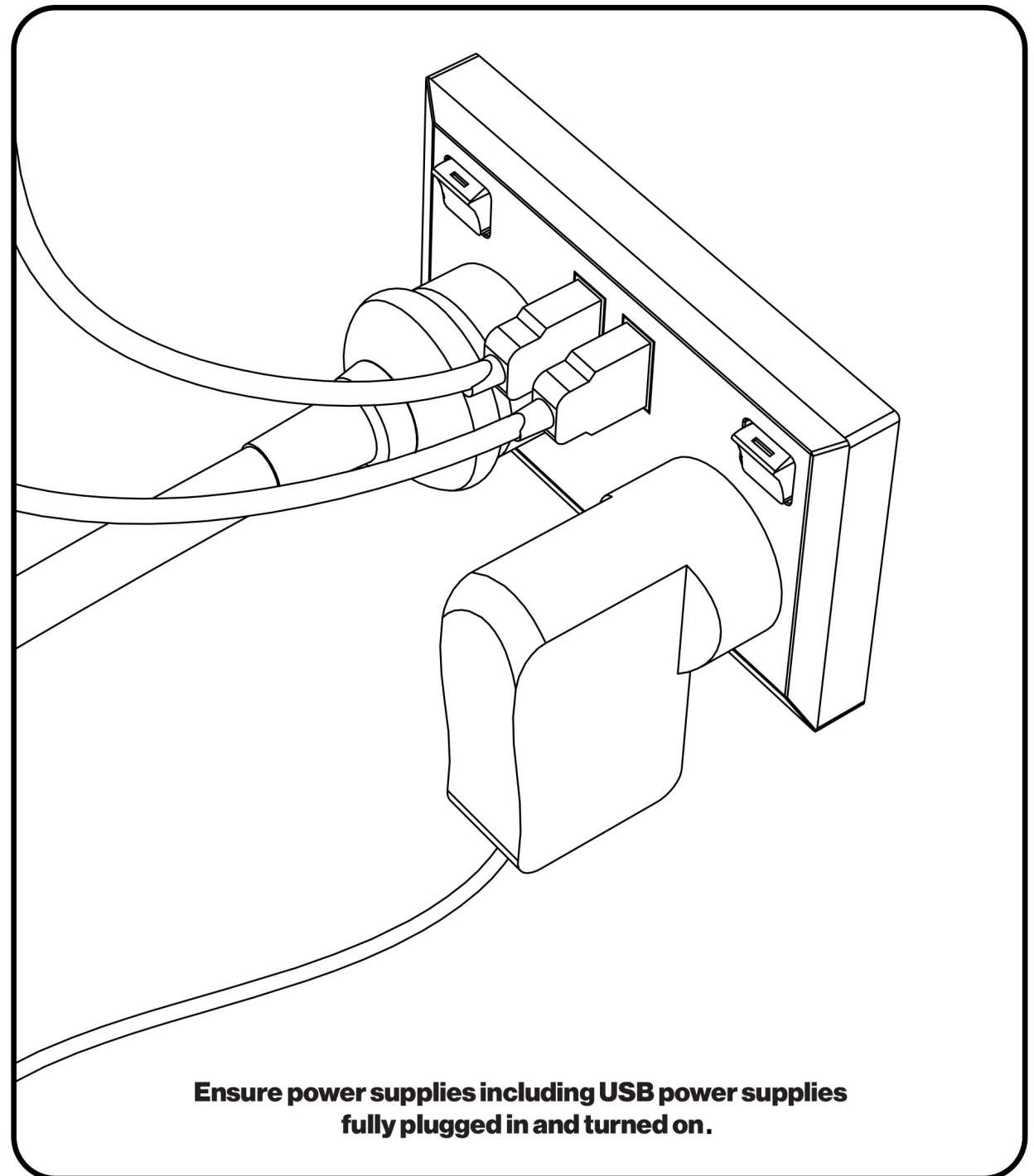
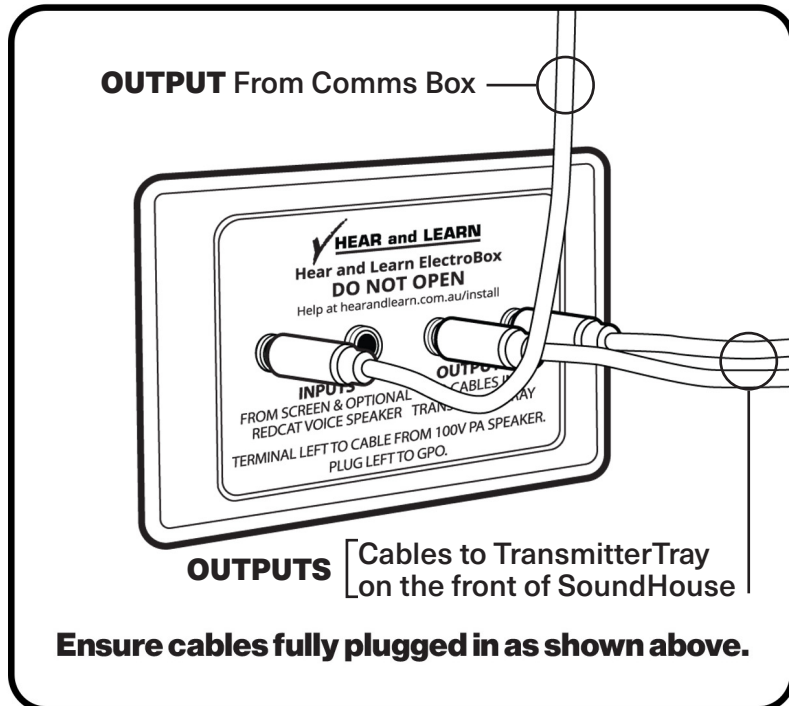

Installation Instructions



SoundHouse

**Recess in Cavity.
As an add on to
Music/Performance
Audio Infrastructure by
Others. With additional
microphones**

*** Position shown for illustration purposes only**

Soundhouse to be accessible to all learners, be in line of sight, and unobscured

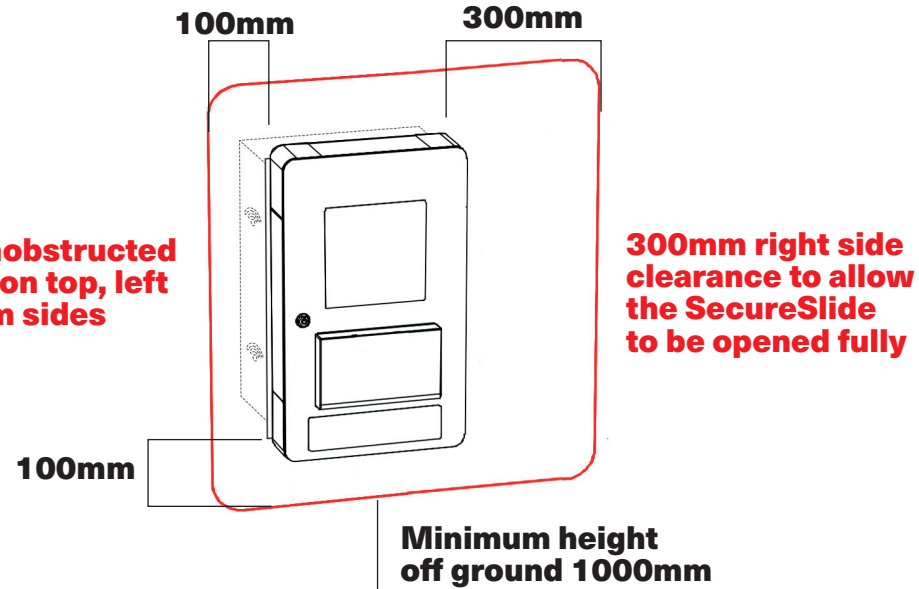

Installation Instructions



SoundHouse

**Recess in Cavity.
As an add on to
Music/Performance
Audio Infrastructure by
Others. With additional
microphones**

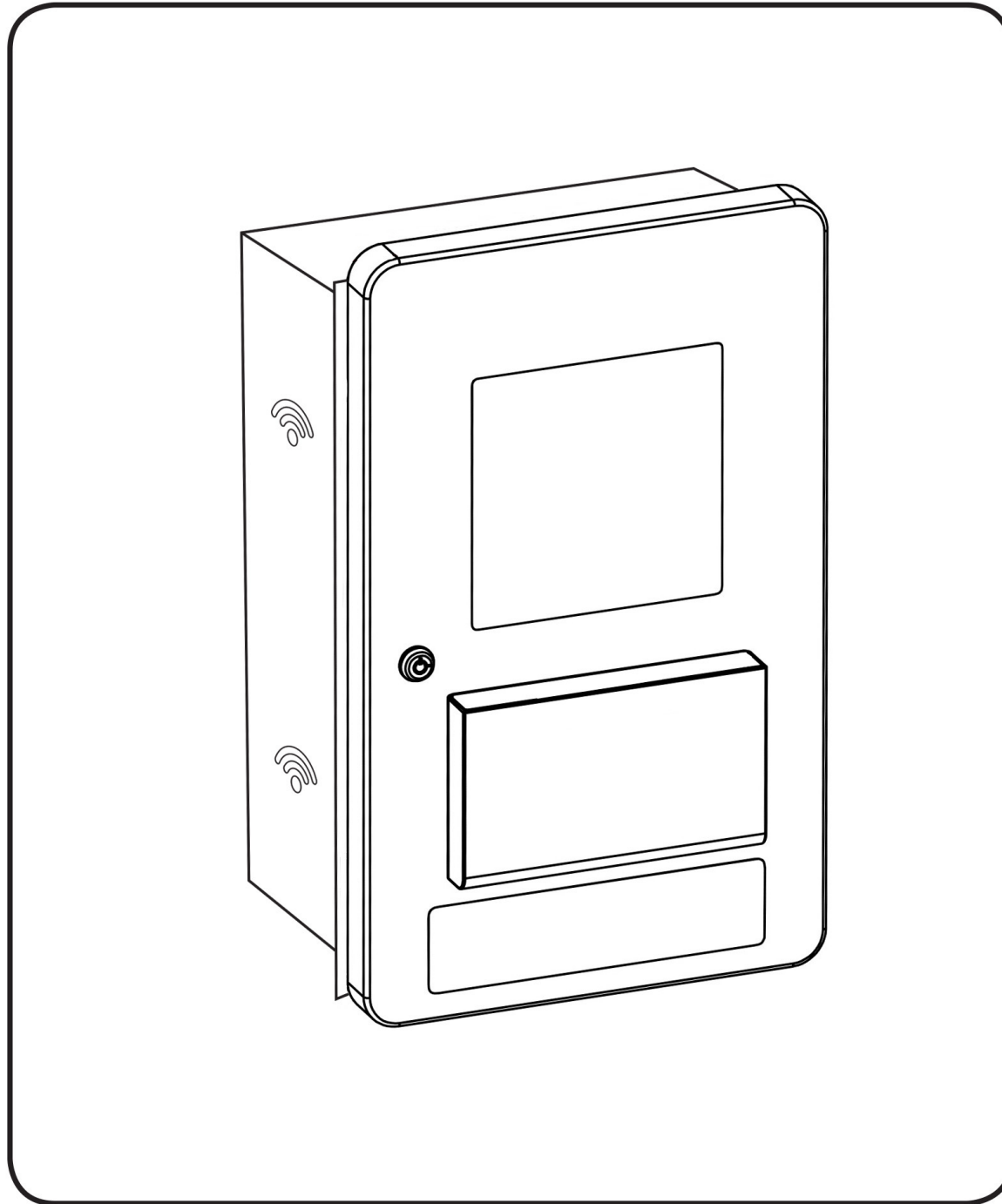

Installation Instructions



SoundHouse

Recess in Cavity.
As an add on to
Music/Performance
Audio Infrastructure by
Others. With additional
microphones

**Cut hole in wall as per 1:1 scale
template link below**

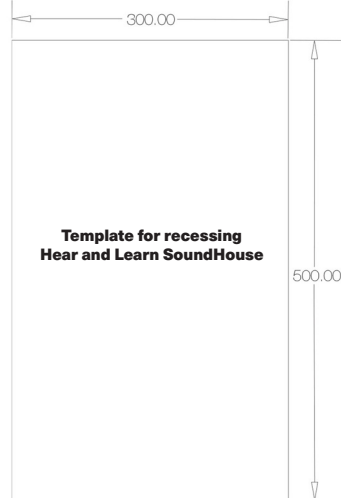

Download installation template at:
hearandlearn.com.au/install

DISCLAIMER*
Installer will be
responsible for
ensuring cavity hole
is cut out neatly so
unseen after flange
and SoundHouse
installed.

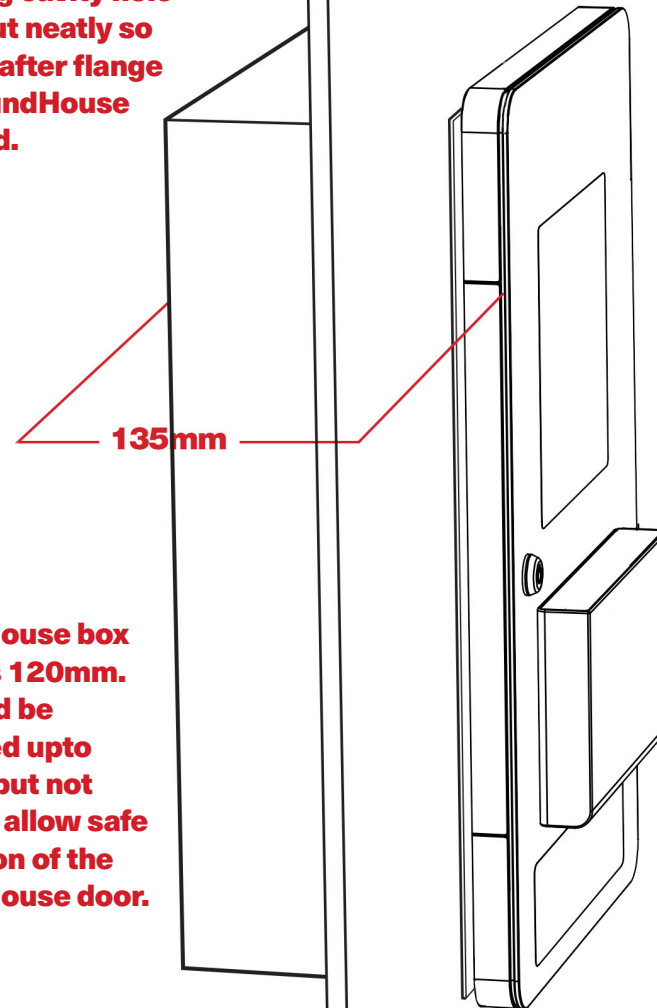

**SoundHouse box
depth is 120mm.
It should be
recessed upto
90 mm but not
more to allow safe
operation of the
SoundHouse door.**

**Door must protrude
by 45mm to allow
door to open freely
on box hinges**

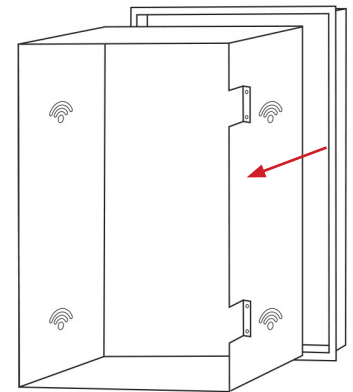

**Slide the cover flange
onto SoundHouse Box
before fixing box to wall
carpentry.**

Installation Instructions



SoundHouse

Recess in Cavity.
As an add on to
Music/Performance
Audio Infrastructure by
Others. With additional
microphones

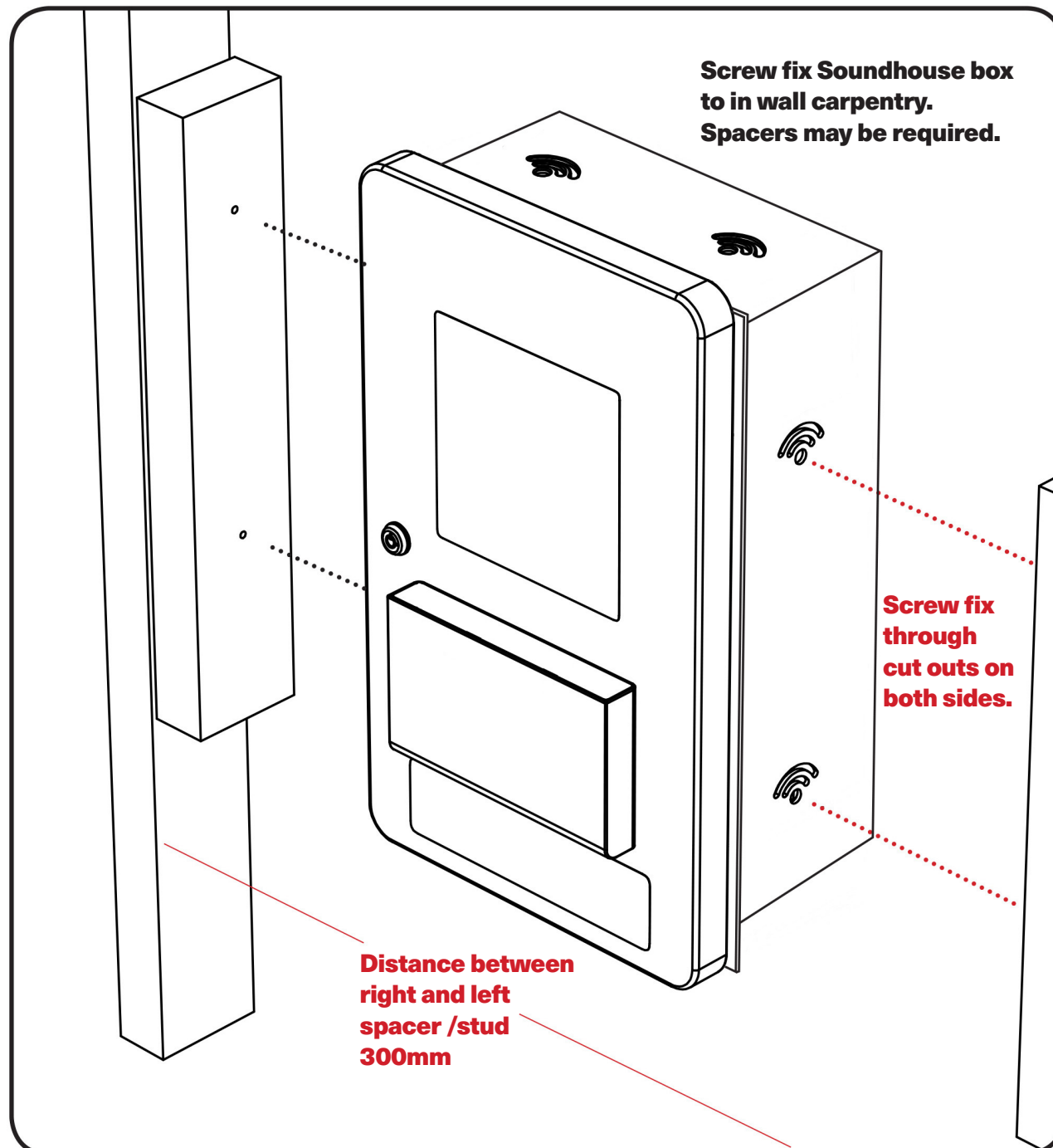
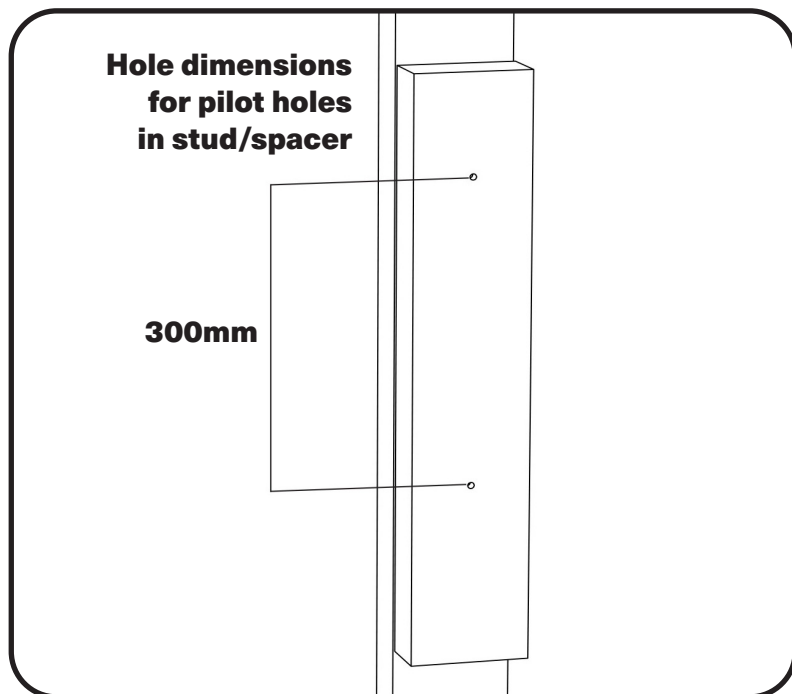

Installation Instructions



SoundHouse

Recess in Cavity.
As an add on to
Music/Performance
Audio Infrastructure by
Others. With additional
microphones

Detailed stud mounting hole location

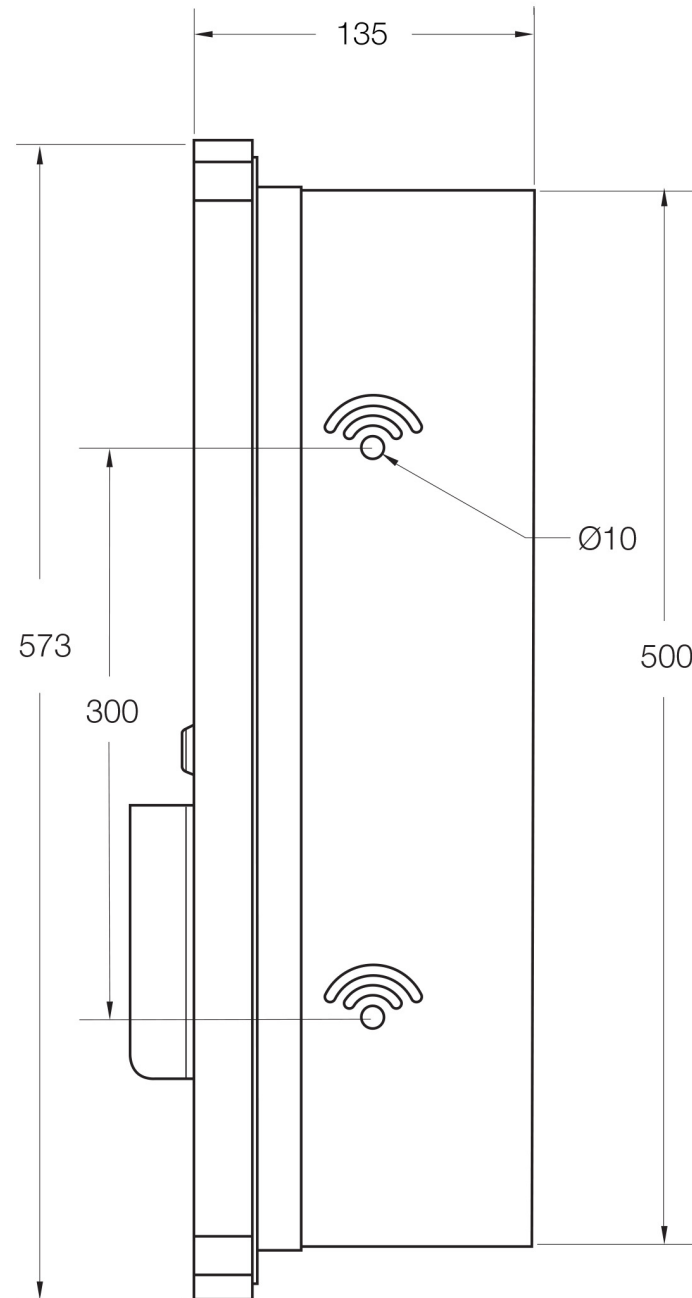

Installation Instructions



SoundHouse

Recess in Cavity.
As an add on to
Music/Performance
Audio Infrastructure by
Others. With additional
microphones

Precabing is to be completed prior to installation of SoundHouse in accordance with electrical diagrams for the project.

All SoundHouses require connection of power to inbuilt GPOs in SoundHouse. Connection of power to SoundHouses to be done by a registered electrician.

Other cables will require connection as per electrical diagrams. These connections may include cable from PA speaker, cable from AV systems and cables to speakers in the learning space. *

SoundHouse has holes in its base for recessed installation.

*Note. Go to Point 2 on Page One for cabling length from AV source to SoundHouse.

NB. Connect 240v power to first internal preinstalled GPO and parallel cable to two other internal preinstalled GPOs. No extra GPOs required for installation.

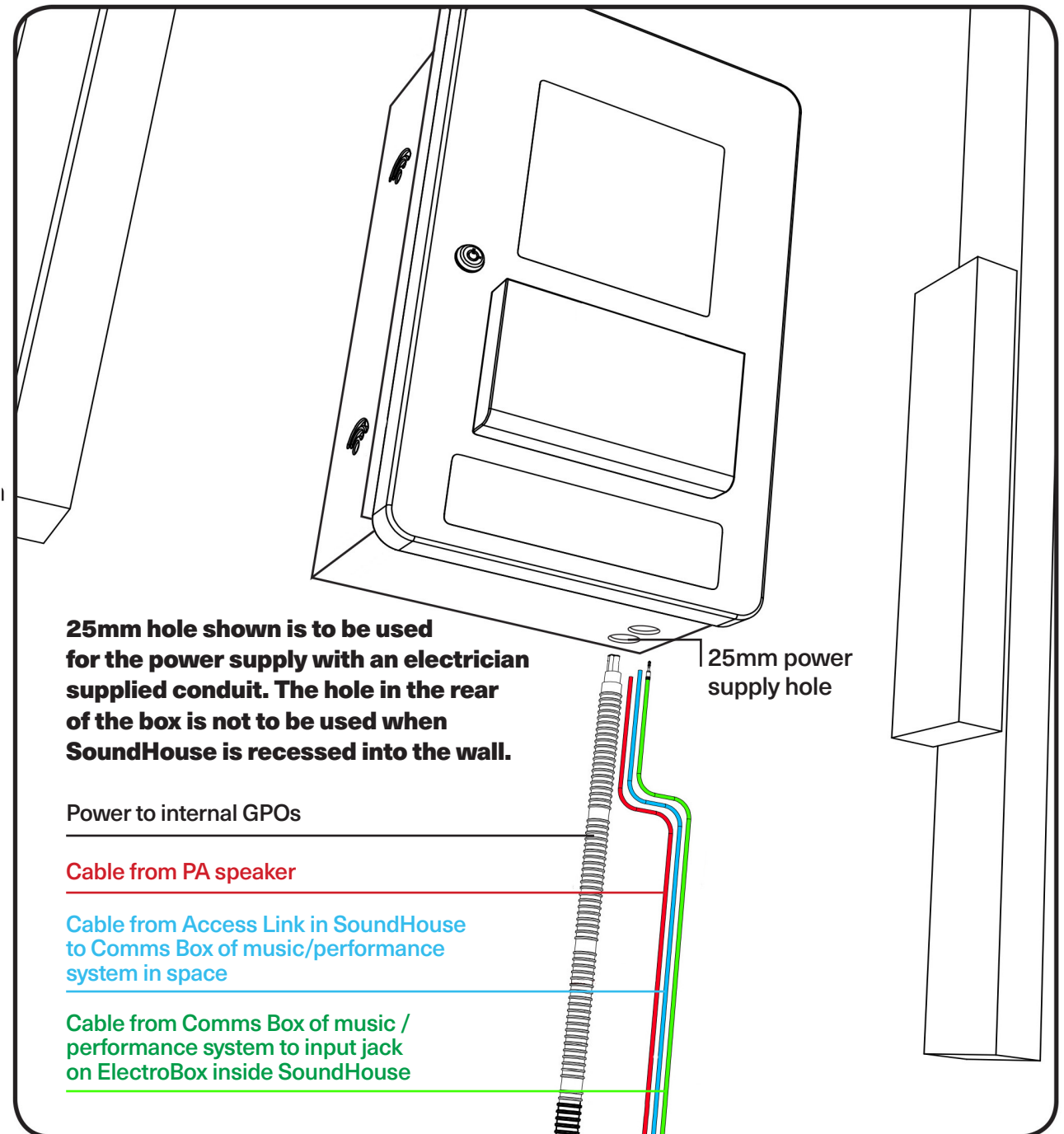

Installation Instructions



SoundHouse

Recess in Cavity.
As an add on to
Music/Performance
Audio Infrastructure by
Others. With additional
microphones

Cable Connection

If your SoundHouse has
Access Link/receiver/microphones

Connect cable
from nearest PA
speaker to allow
augmentation
of PA audio

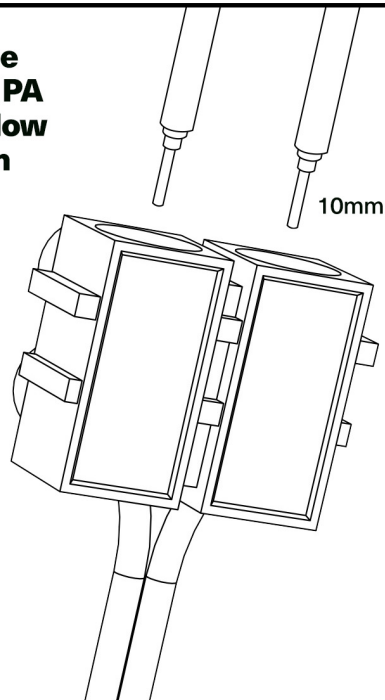

See speaker cabling instructions at
hearandlearn.com.au/install

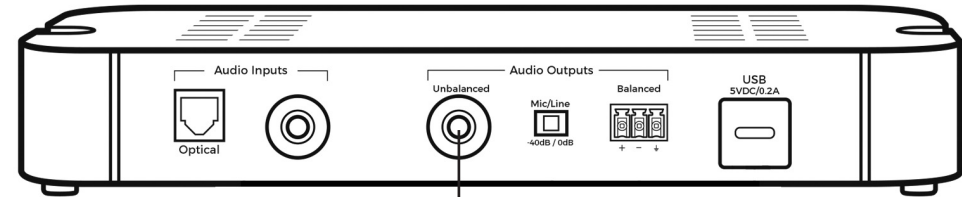

Output from Access
Link to amp input
in Comms Box for
gym speakers

Installation Instructions



SoundHouse

**Recess in Cavity.
As an add on to
Music/Performance
Audio Infrastructure by
Others. With additional
microphones**

Cable Connection

If your SoundHouse has
Access Link/receiver/microphones

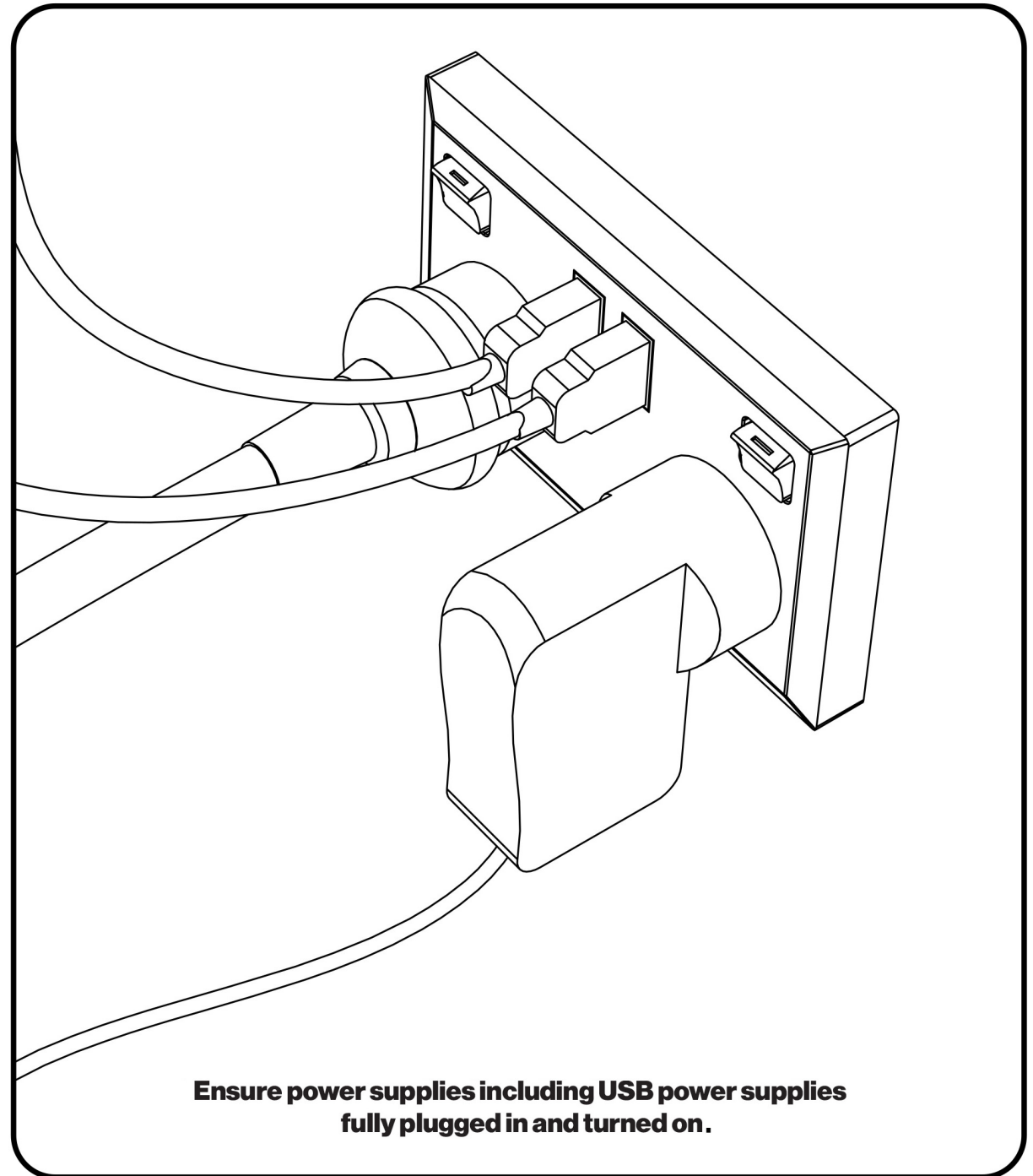
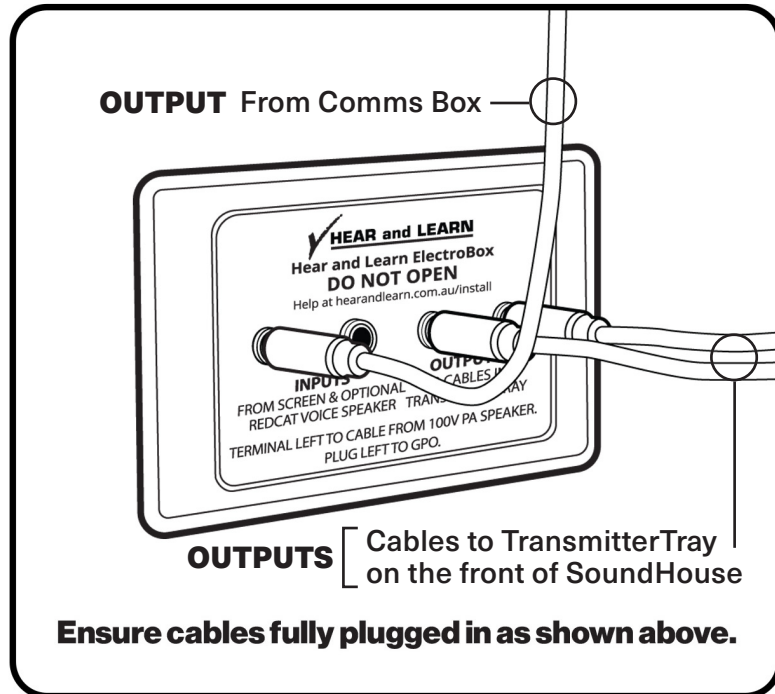

Installation Instructions



SoundHouse

**Recess in Cavity.
As an add on to
Music/Performance
Audio Infrastructure by
Others. With additional
microphones**

Use UConnect in this space to receive audio. Extra transmitters and receivers at Admin.



Use UConnect in this space to receive audio. Extra transmitters and receivers at Admin.

UConnect

www.hearandlearn.com.au

Base of sign must be located not less than 1200mm and not higher than 1600mm above the floor or ground surface

AND

On the wall on the latch side of the door with the leading edge of the sign located between 50mm and 300mm from the architrave; and where this is not possible, the sign may be placed on the door itself.

*** Actual language on sign may vary**

