

# Hear and Learn Speaker Wiring Instructions for 975 Amp receiver

Red cables are positive. Black cables are negative. Blue cables are bridging cables



**DRQ SPEAKER**

DRQ for flat plaster/tiles ceilings between 2700 & 3700 mm from floor



**PENDANT SPEAKER**

Pendant speaker for pitched ceilings/those with voids/ceilings higher than 3700mm from floor

Speakers mounted in ceiling tiles need to be installed safely. Speakers should be equally spaced for even sound distribution. Pendant speakers need to be mounted out of reach.

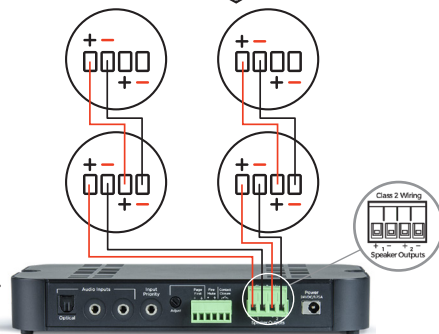
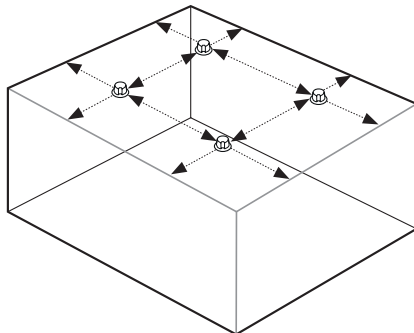

975 Amp Rear  
Wiring to 4 x 8 ohm speakers

IF CONNECTING SPEAKERS TO 975 IN SOUNDHOUSE, 975 WILL BE MOUNTED VERTICALLY



**WMQ SPEAKER**

Depending on ceiling height, speakers should be mounted 2.35m to 3.75m from the floor and 1/3 in from each corner of the room. No two speakers should be directly across from one another. Wall speakers must be mounted out of reach.

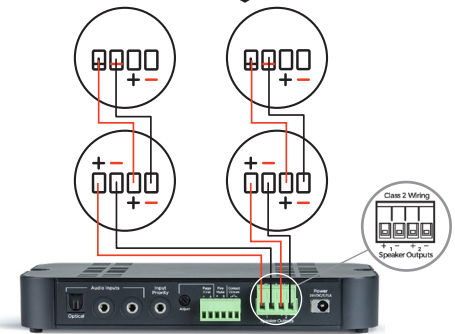
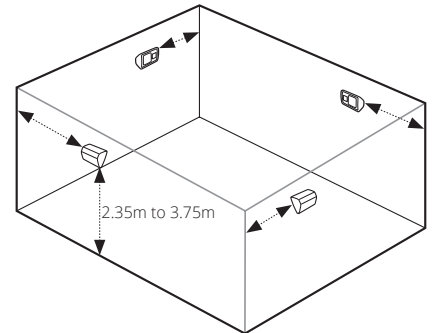

975 Amp Rear  
Wiring to 4 x 8 ohm speakers

IF CONNECTING SPEAKERS TO 975 IN SOUNDHOUSE, 975 WILL BE MOUNTED VERTICALLY



**TCQN SPEAKER**

Single speaker mounted safely in ceiling tile with supplied brackets. Do not install directly above a physical obstacle such as a hanging light fixture or HVAC duct.

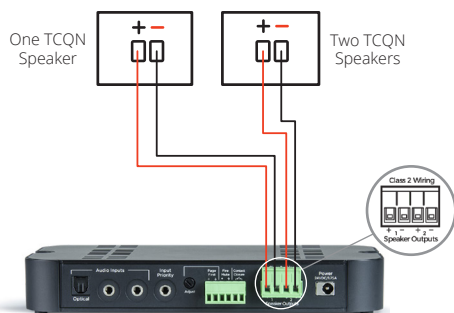
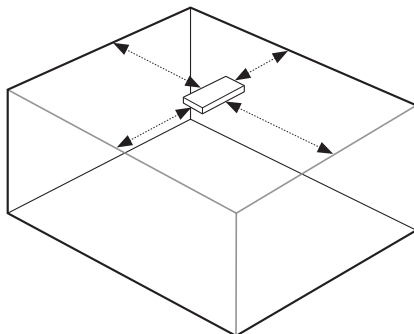

975 Amp Rear  
All speaker wiring. 2 Cond/18 Awg

IF CONNECTING SPEAKERS TO 975 IN SOUNDHOUSE, 975 WILL BE MOUNTED VERTICALLY

**PENDANT SPEAKER**



Pendant speaker comes supplied with cable which has seven smaller cables within it of various colours (to allow for connection to various types of amplifiers). For connection to our 975 amplifier, use red cable (as the positive) and black cable (as the negative).

It is the responsibility of the installer to test cabling, and any rework as a result of incorrect cabling, and to determine that speakers are installed safely and in accordance with architect / electrical consultants instructions.

# Hear and Learn Speaker Wiring Instructions for 975 Amp receiver

Red cables are positive. Black cables are negative. Blue cables are bridging cables



WMQ SPEAKER



DRQ SPEAKER  
DRQ for flat plaster/tiles ceilings between 2700 & 3700 mm from floor



PENDANT SPEAKER  
Pendant speaker for pitched ceilings/those with voids/ceilings higher than 3700mm from floor

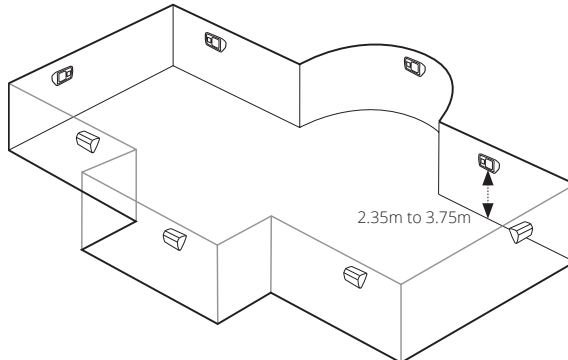

Depending on ceiling height, speakers should be mounted 2.35m to 3.75m from the floor and 1/3 in from each corner of the room. No two speakers should be directly across from one another. Wall speakers must be mounted out of reach.

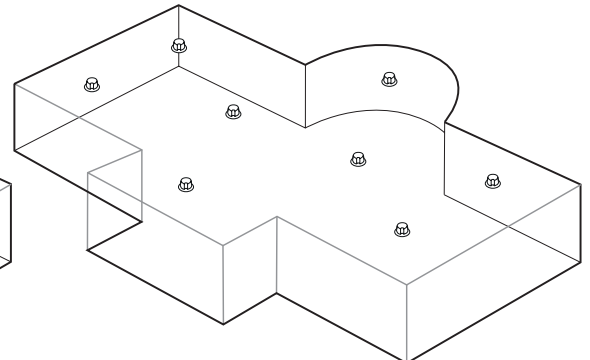

Speakers mounted in ceiling tiles need to be installed safely. Speakers should be equally spaced for even sound distribution. Pendant speakers need to be mounted out of reach.

## WIRING TO SIX SPEAKERS

For both wall mounted, ceiling mounted and pendant speakers. (see page 1 for unique install instructions)

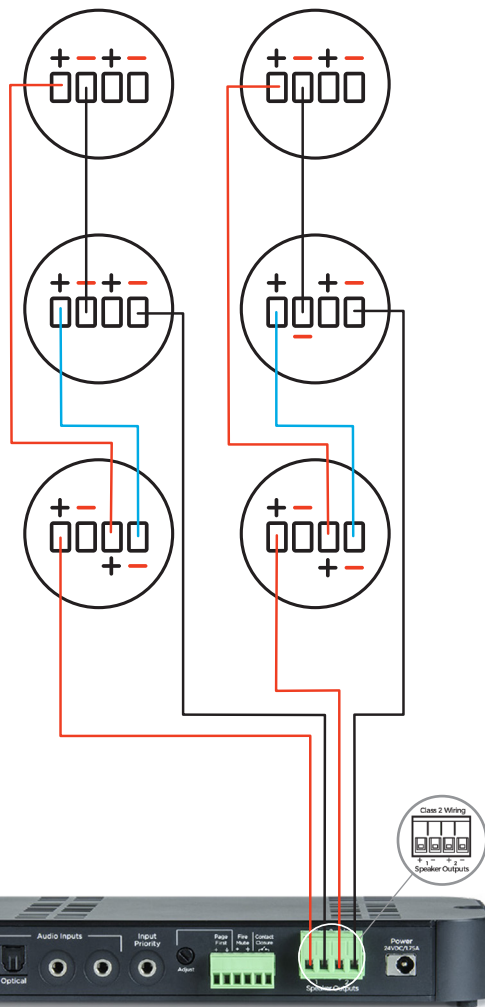

975 Amp Rear

Wiring to 6 x 8 ohm speakers

## WIRING TO EIGHT SPEAKERS

For both wall mounted, ceiling mounted and pendant speakers. (see page 1 for unique install instructions)

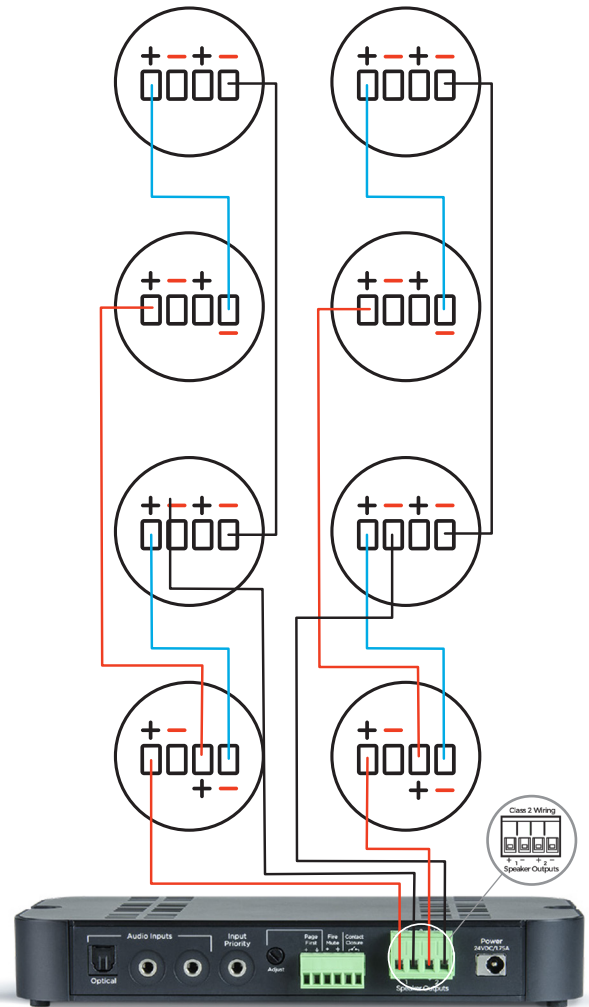

975 Amp Rear

Wiring to 8 x 8 ohm speakers

IF CONNECTING SPEAKERS TO 975 IN SOUNDHOUSE, 975 WILL BE MOUNTED VERTICALLY

IF CONNECTING SPEAKERS TO 975 IN SOUNDHOUSE, 975 WILL BE MOUNTED VERTICALLY

## Hear and Learn Wiring RedCat to UConnect Mini

Cabling via 3.5 mm to 3.5 mm plug cable or CAT6 with audio extenders from Uconnect Mini location to Wall Plate with 3.5 mm socket under mounting location of Redcat Access

### UCONNECT MINI



Input from Screen Audio

**Left.** 3.5 mm plug cable from RedCat wallplate to UConnect Mini input.  
**Right.** Input from Screen Audio

### UCONNECT MINI PRE BUILT AND INSTALLED ELECTRONICS HUB

- 1 Bespoke electronics hub with 100v to line level converter for input from local PA speaker, PA priority over other inputs. Input from Screen Audio, and two outputs to transmitters to hearing aids.
- 2 Dual GPO with dual USB output for powering electronics hub and transmitters to hearing aids.

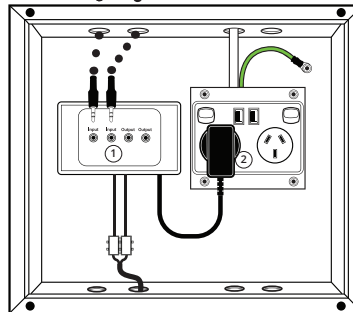

### CABLE LENGTH

Cable input from screen to 3.5 female stereo socket. Where cable length from AV device to rear of UConnect Mini is less than 10 metres, run a 3.5mm stereo male cable supplied and installed by others. Where cable length from AV device to rear of UConnect Mini is more than 10 metres, run CAT6 (supplied and installed by others) and at each end connect audio extenders (supplied and installed by others). Connection of cable to AV source to be determined and completed by others.

### WALL MOUNTED REDCAT

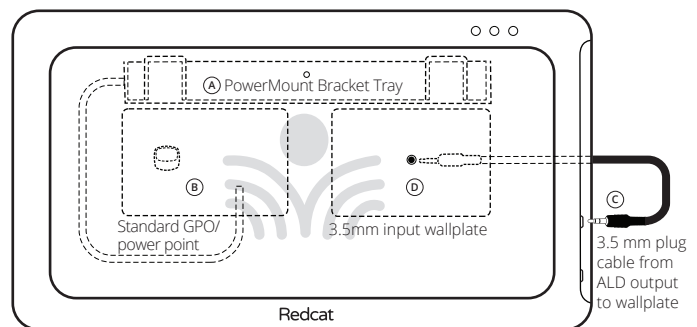

**Front view**  
Showing position of concealed GPO  
& Input wallplate (dotted lines)

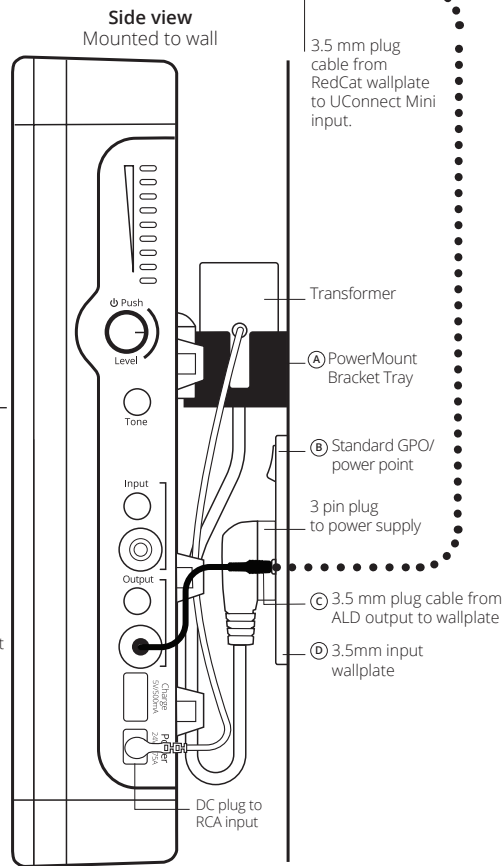

**PowerMount**

The PowerMount system means the Redcat conceals the wallplate and GPO for an aesthetically pleasing and tamper free solution. For the Powermount installation guide go to [hearandlearn.com.au/storage](http://hearandlearn.com.au/storage) or use the QR code.

